

NUEVO CATÁLOGO DE DISCOS 2024

carboceramic



WWW.CIOSA.CO

DISCOS DE FRENO

GEOMET COATING RANURADOS

CARACTERÍSTICAS Y BENEFICIOS

MEJORA EL ASPECTO VISUAL
INCREMENTA FRENADO INICIAL
ALARGA LA VIDA ÚTIL
DEL DISCO

ACERO ALTO CARBONO

EL DISCO NO SE DEFORMA
EVITA VIBRACIONES
CONFORT AL FRENAR

RANURAS

INCREMENTA EFICIENCIA DE
FRENADO
PASTILLAS MÁS LIMPIAS

ECE R90-2

REGULACIÓN EUROPEA PARA
DISCOS DE FRENO
CERTIFICA UN REEMPLAZO DE
EQUIPO ORIGINAL

ALABES

ACORDE A EOM
GARANTIZAN MEJOR ENFRIAMIENTO
DISMINUYEN RUIDOS



WWW.CIOSA.CO

**LA MEJOR CALIDAD CON EL PRECIO
MÁS COMPETITIVO**



DISCOS DE FRENO

SMOOTH FINISHED

CARACTERÍSTICAS Y BENEFICIOS

ACABADO SMOOTH
BALANCEADO
MEJORA EL ASENTAMIENTO

ACERO ALTO CARBONO

EL DISCO NO SE DEFORMA
EVITA VIBRACIONES
CONFORT AL FRENAR

BALANCEADOS

GARANTIZADO ANTE VIBRACIONES

ECE R90-2

REGULACIÓN EUROPEA PARA
DISCOS DE FRENO
CERTIFICA UN REEMPLAZO DE
EQUIPO ORIGINAL

ALABES

ACORDE A EOM
GARANTIZAN MEJOR ENFRIAMIENTO
DISMINUYEN RUIDOS



WWW.CIOSA.CO

**LA MEJOR CALIDAD CON EL VALOR
MÁS COMPETITIVO**



DNKD1456STH

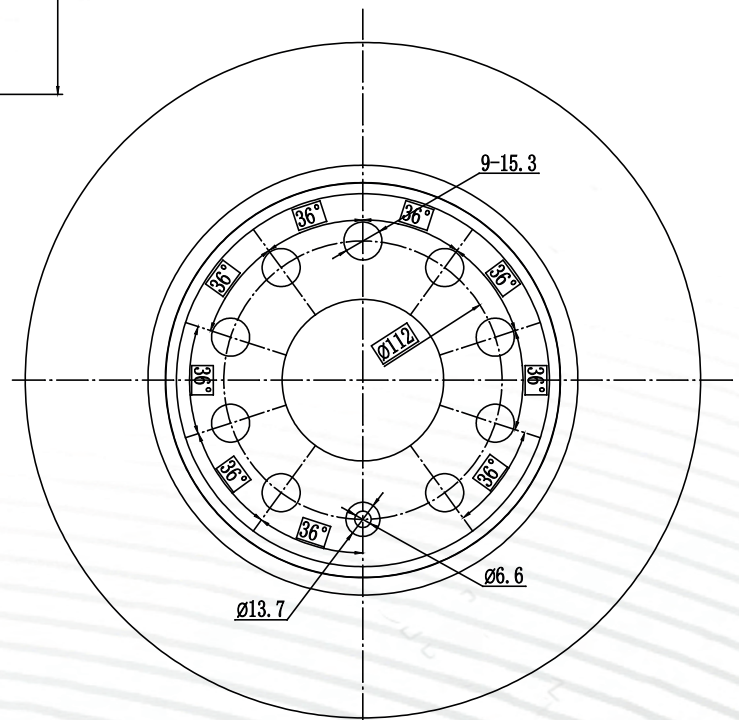
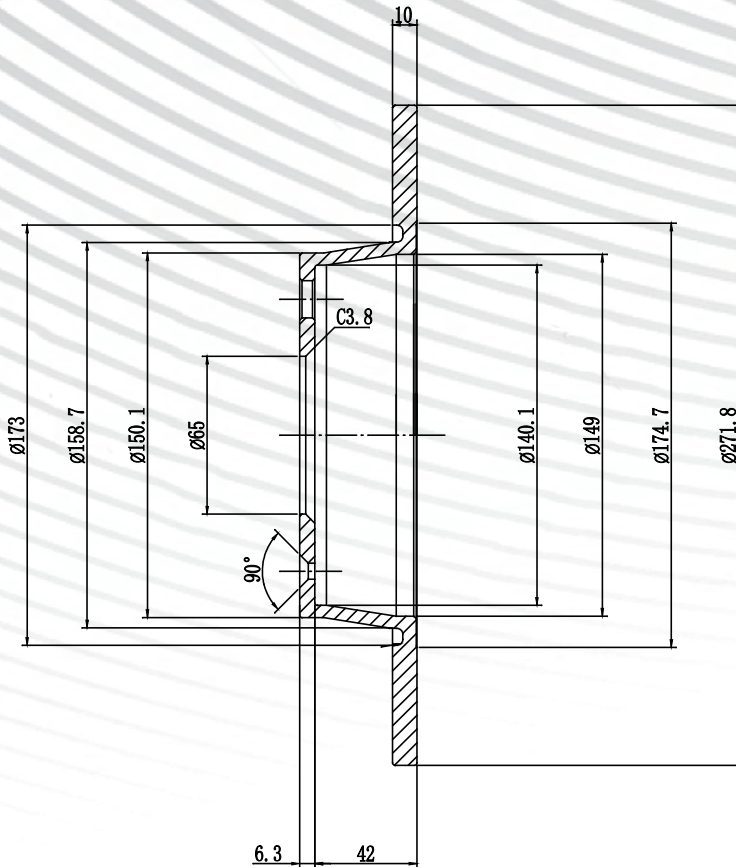

NPC DYNAMIK	FORMULACIÓN	ARMADORA	FREMAX	AÑO	DIÁMETRO	ALTO	ESPESOR	EJE
DNKD1456STH	SMOOTH	AUDI	BD5637	12/...	271,8 mm	48,3 mm	10 mm	TRASERO
APLICACIÓN								
AUDI A1 2012 ; AUDI A3 SPORTBACK 2004-2010 ; SEAT ALTEA 2006 ; SEAT LEON 2009 ; SKODA OCTAVIA 2009-2010 ; SKODA SUPERB 2008 ; SKODA YETI 2010 ; VOLKSWAGEN BEETLE 2012 ; VOLKSWAGEN GOLF VI-VII 2009-2015 ; VOLKSWAGEN JETTA III 2007-2016 ;								

DNKD296STH

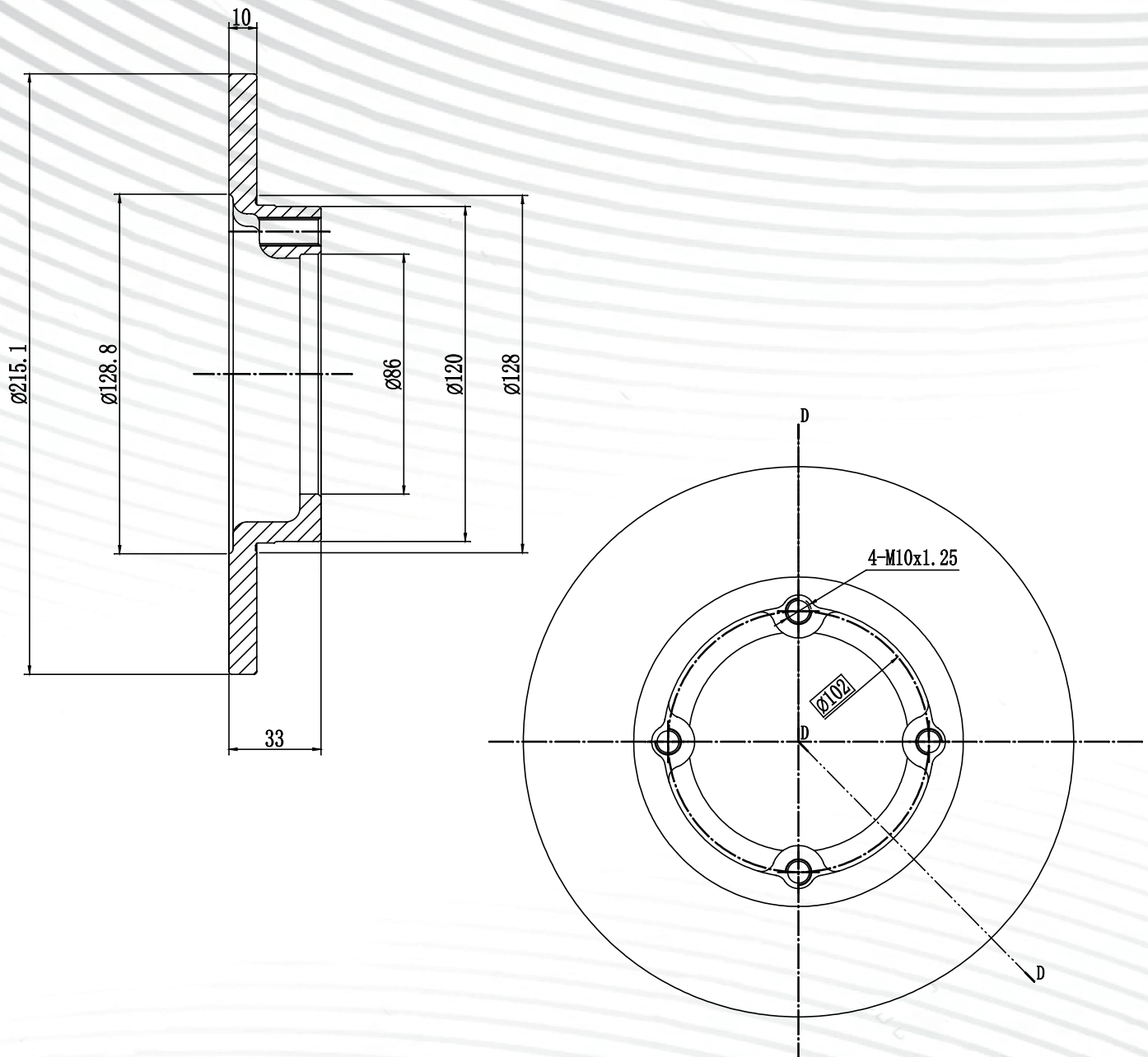

NPC DYNAMIK	FORMULACIÓN	ARMADORA	FREMAX	AÑO	DIÁMETRO	ALTO	ESPESOR	EJE
DNKD296STH	SMOOTH	CHEVROLET	BD1160	87/07	215,1 mm	33 mm	10 mm	DELANTERO
APLICACIÓN								
CHEVROLET SPRINT 1987-2007 ; CHEVROLET SUPER CARRY 1999 ; DAEWOO TICO 1985 ; DAEWOO DAMAS 1993 ; SUZUKI ALTO 1988-1993 ; SUZUKI SWIFT 1984-1989								

DNKD451STH

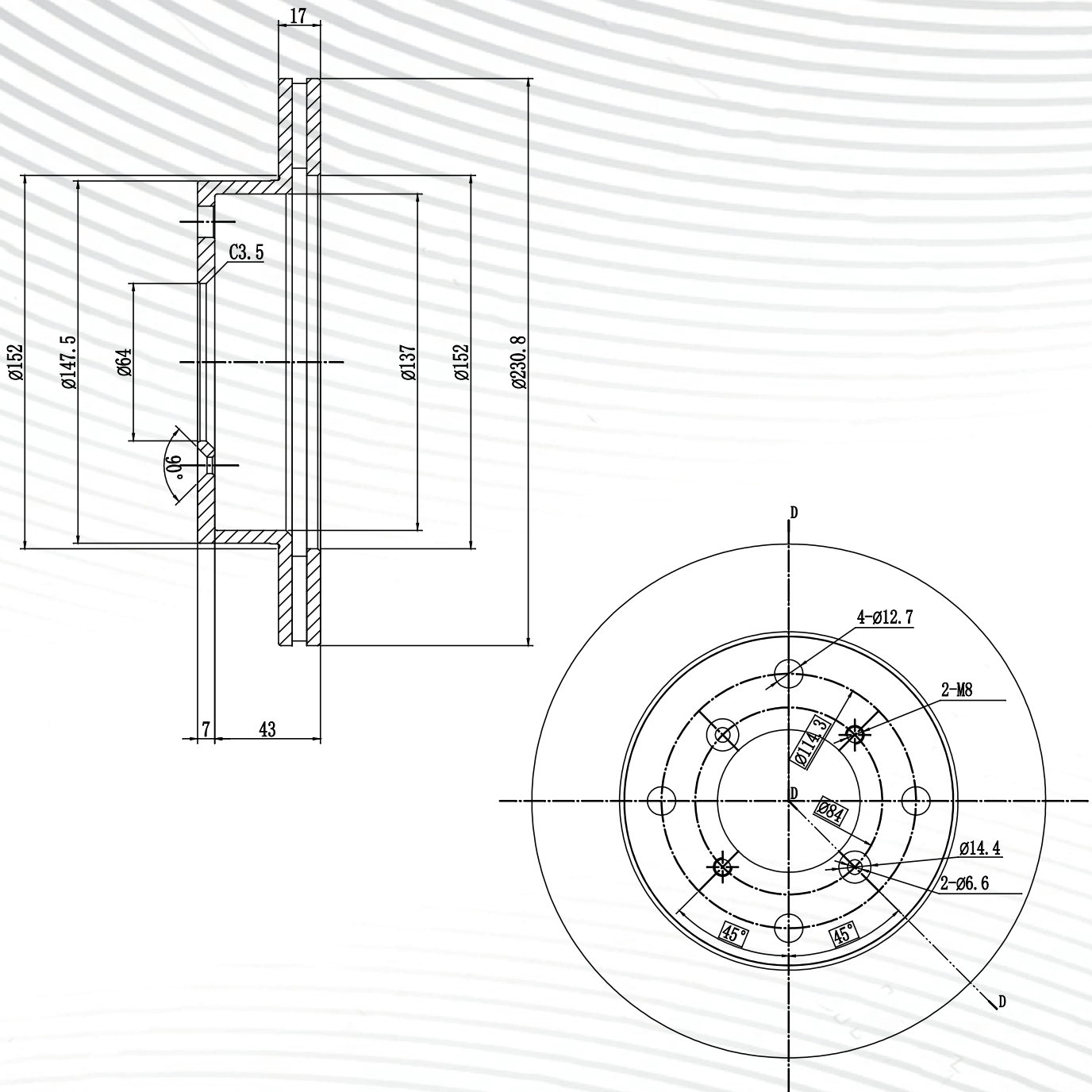

NPC DYNAMIK	FORMULACIÓN	ARMADORA	FREMAX	AÑO	DIÁMETRO	ALTO	ESPESOR	EJE
DNKD451STH	SMOOTH	CHEVROLET	BD6030	TODOS	230,8 mm	50 mm	17 mm	DELANTERO
APLICACIÓN								
SWIFT 1.3 cc								

DNKD677STH

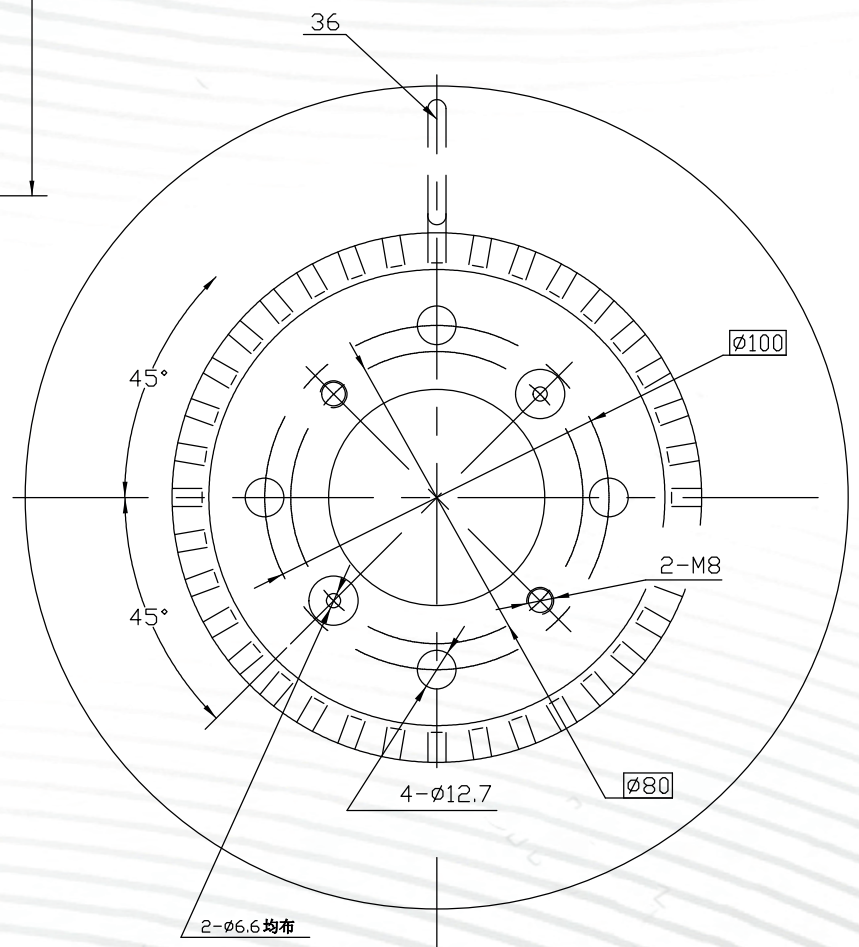
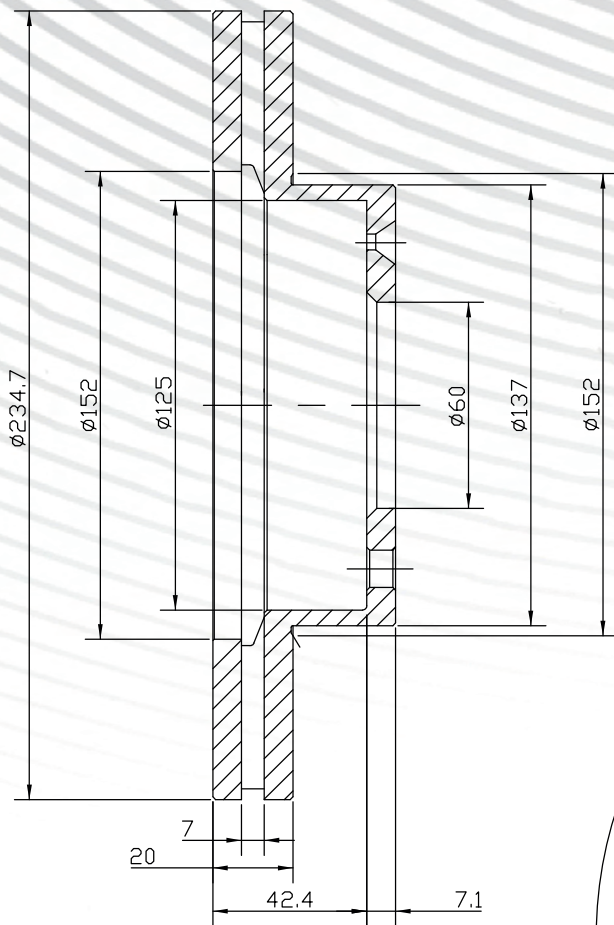

NPC DYNAMIK	FORMULACIÓN	ARMADORA	FREMAX	AÑO	DIÁMETRO	ALTO	ESPESOR	EJE
DNKD677STH	SMOOTH	CHEVROLET	BD6101	96/04	234,7 mm	49,5 mm	20 mm	DELANTERO
APLICACIÓN								
ESTEEM 1.3cc, 1.6cc, 1.6 SW								

DNKD1321STH

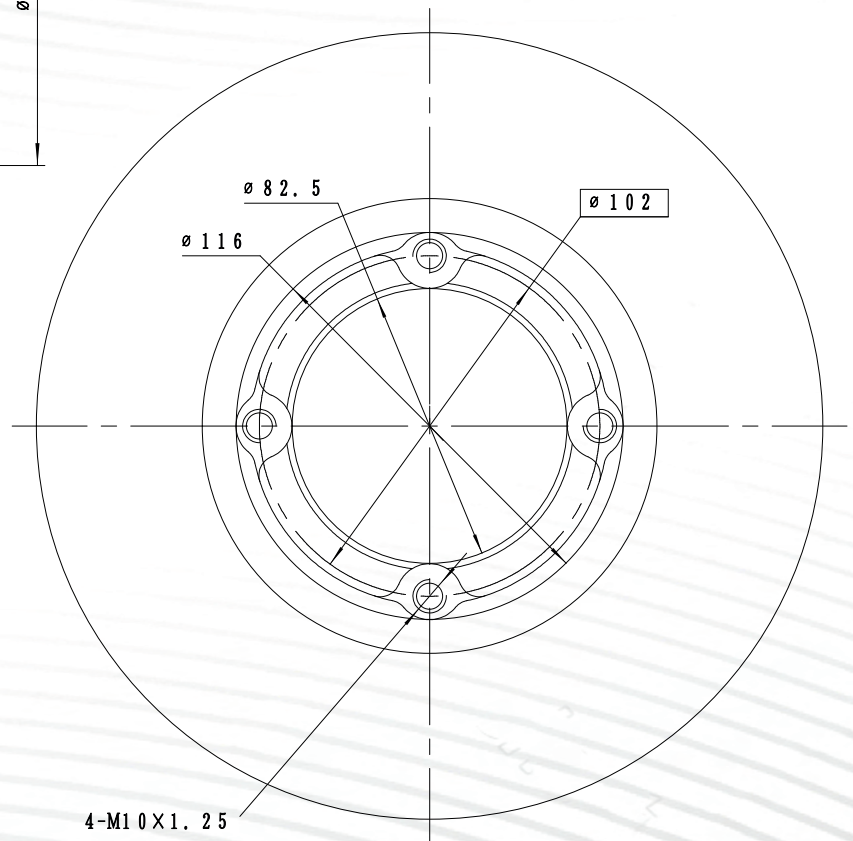
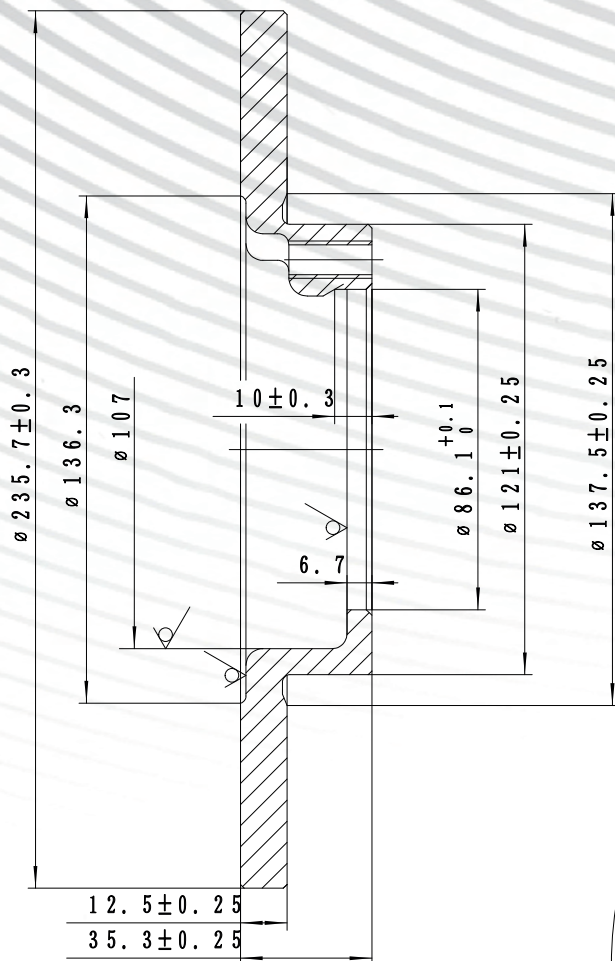

NPC DYNAMIK	FORMULACIÓN	ARMADORA	FREMAX	AÑO	DIÁMETRO	ALTO	ESPESOR	EJE
DNKD1321STH	SMOOTH	CHEVROLET	BD4392	TODOS	235,7 mm	35,3 mm	12,5 mm	DELANTERO
APLICACIÓN								
SPARK LT/GO 7:24 TAXI Y CHRONOS								

DNKD1661STH

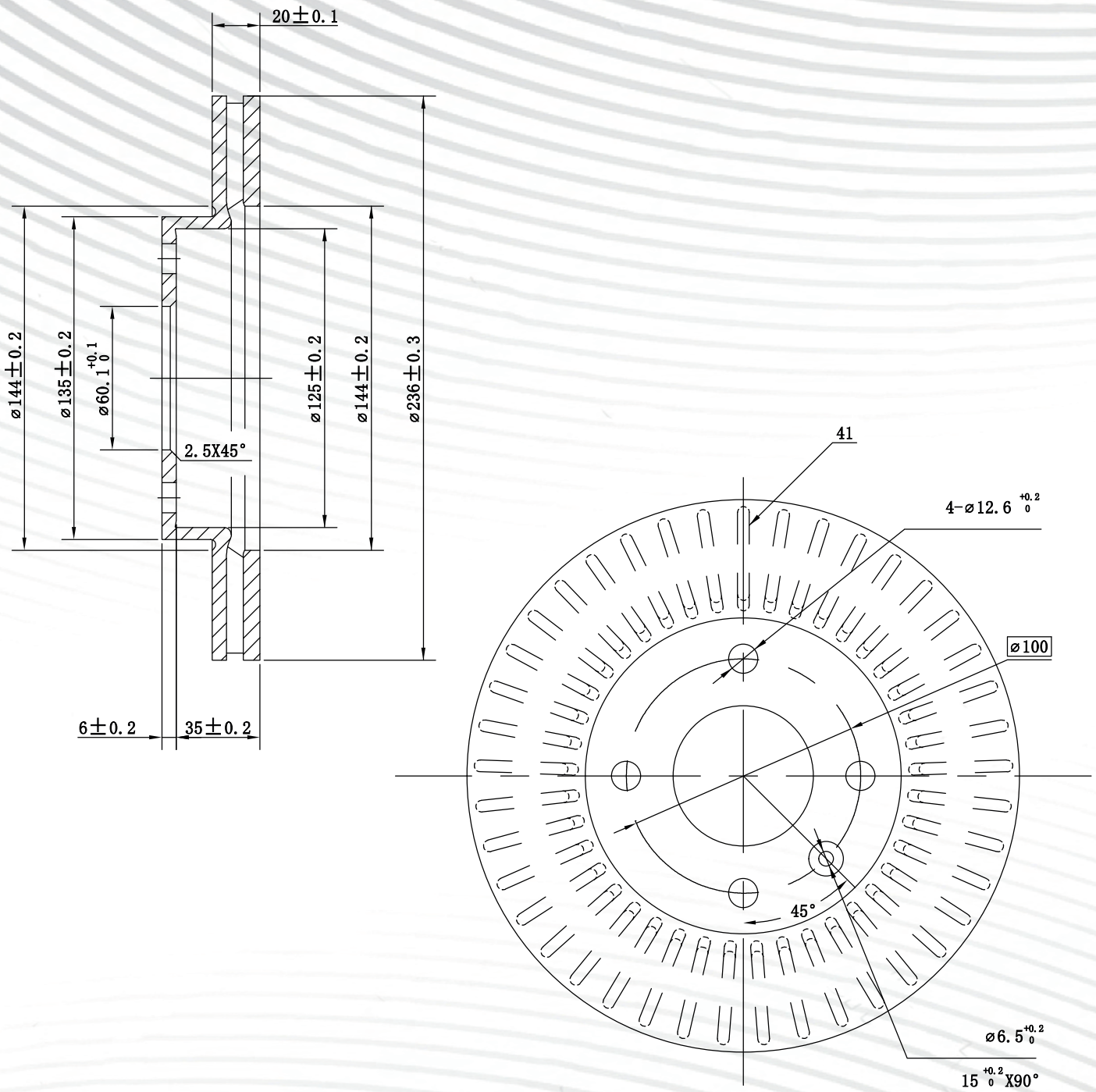

NPC DYNAMIK	FORMULACIÓN	ARMADORA	FREMAX	AÑO	DIÁMETRO	ALTO	ESPESOR	EJE
DNKD1661STH	SMOOTH	CHEVROLET	BD1570	10/...	236 mm	41 mm	20 mm	DELANTERO
APLICACIÓN								
SAIL 1.4cc 16 val								

DNKD688STH

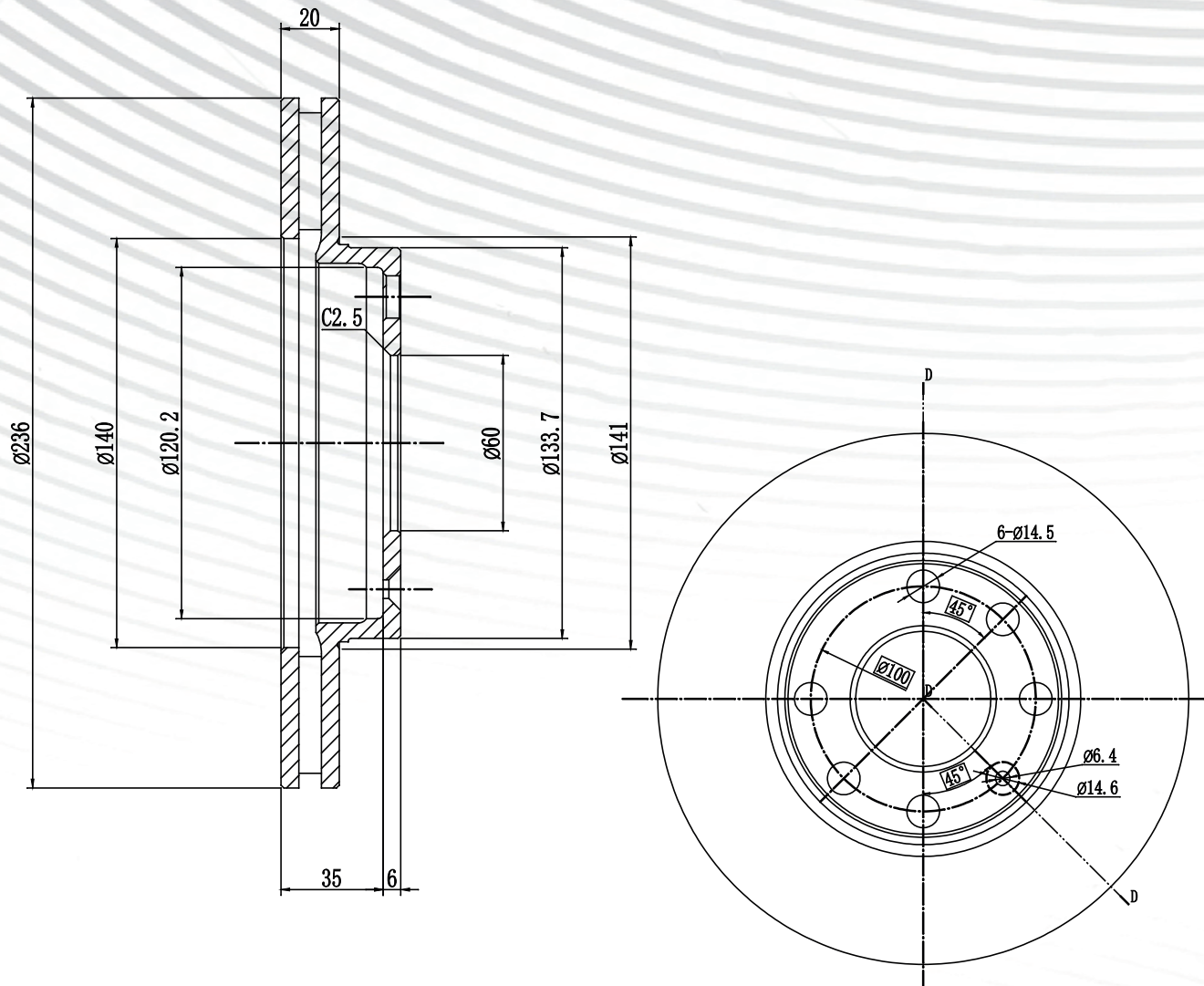

NPC DYNAMIK	FORMULACIÓN	ARMADORA	FREMAX	AÑO	DIÁMETRO	ALTO	ESPESOR	EJE
DNKD688STH	SMOOTH	CHEVROLET	BD1440	02/09 94/97 98/02 04/06 02/04 02/08 85/87 88/92	236 mm	41 mm	20 mm	DELANTERO
APLICACIÓN								
CHEVY C2 1.6cc / CHEVY COMFORT 1.6cc CORSA 1.3cc / CORSA 1.4cc CORSA TAXI POWER 1.6cc / CORSA 1.7cc Diesel CORSA 1.4cc @CTIVE / WIND MONZA I 1.8cc / MONZA II 2.0 cc MONZA II 2.0 cc								

DNKD1176STH

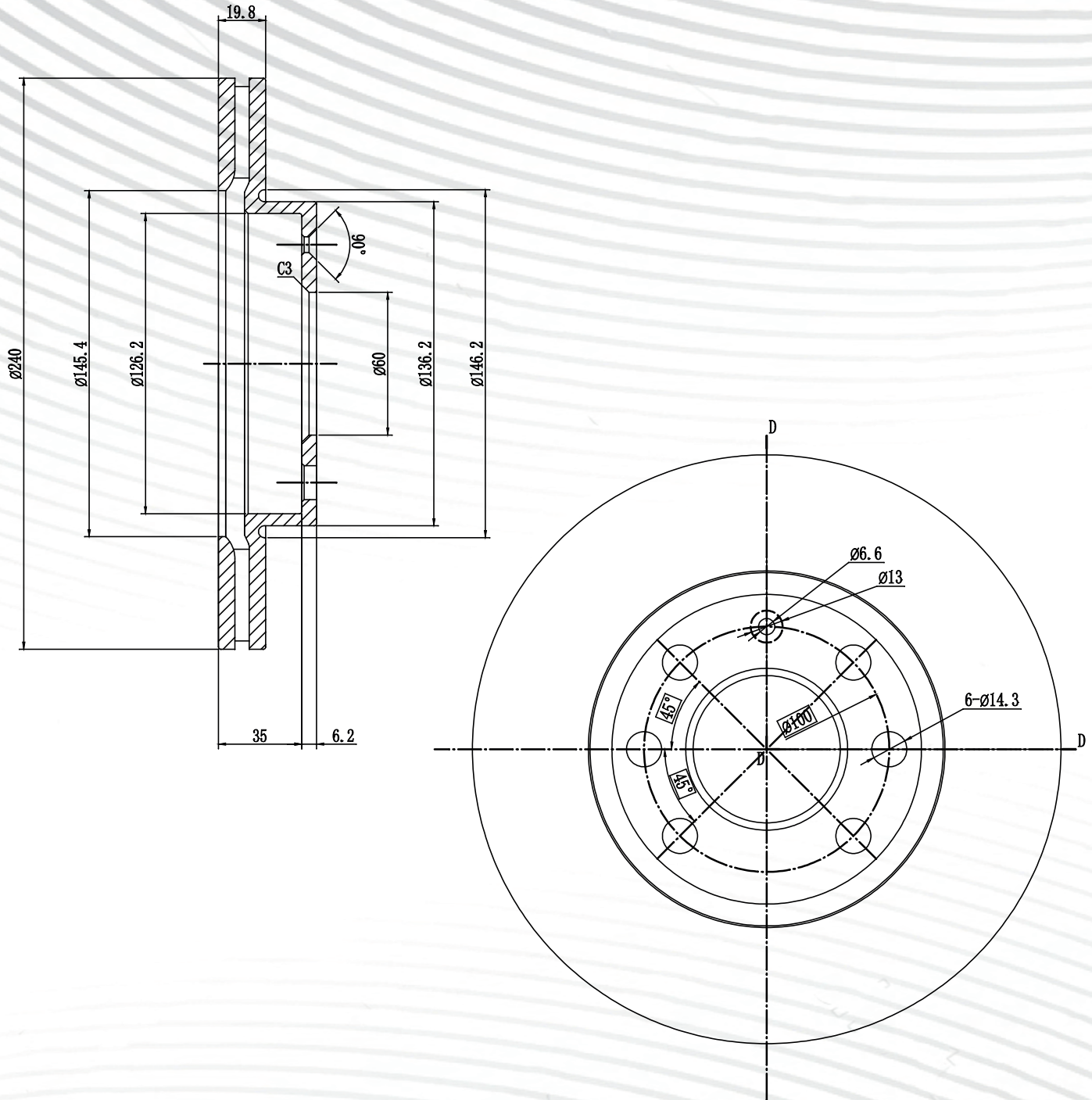

NPC DYNAMIK	FORMULACIÓN	ARMADORA	FREMAX	AÑO	DIÁMETRO	ALTO	ESPESOR	EJE
DNKD1176STH	SMOOTH	CHEVROLET	BD7966	03/07	240 mm	41,2 mm	19,8 mm	DELANTERO
APLICACIÓN								
CORSA EVOLUTION 1.4cc TODOS								

DNKD1677STH

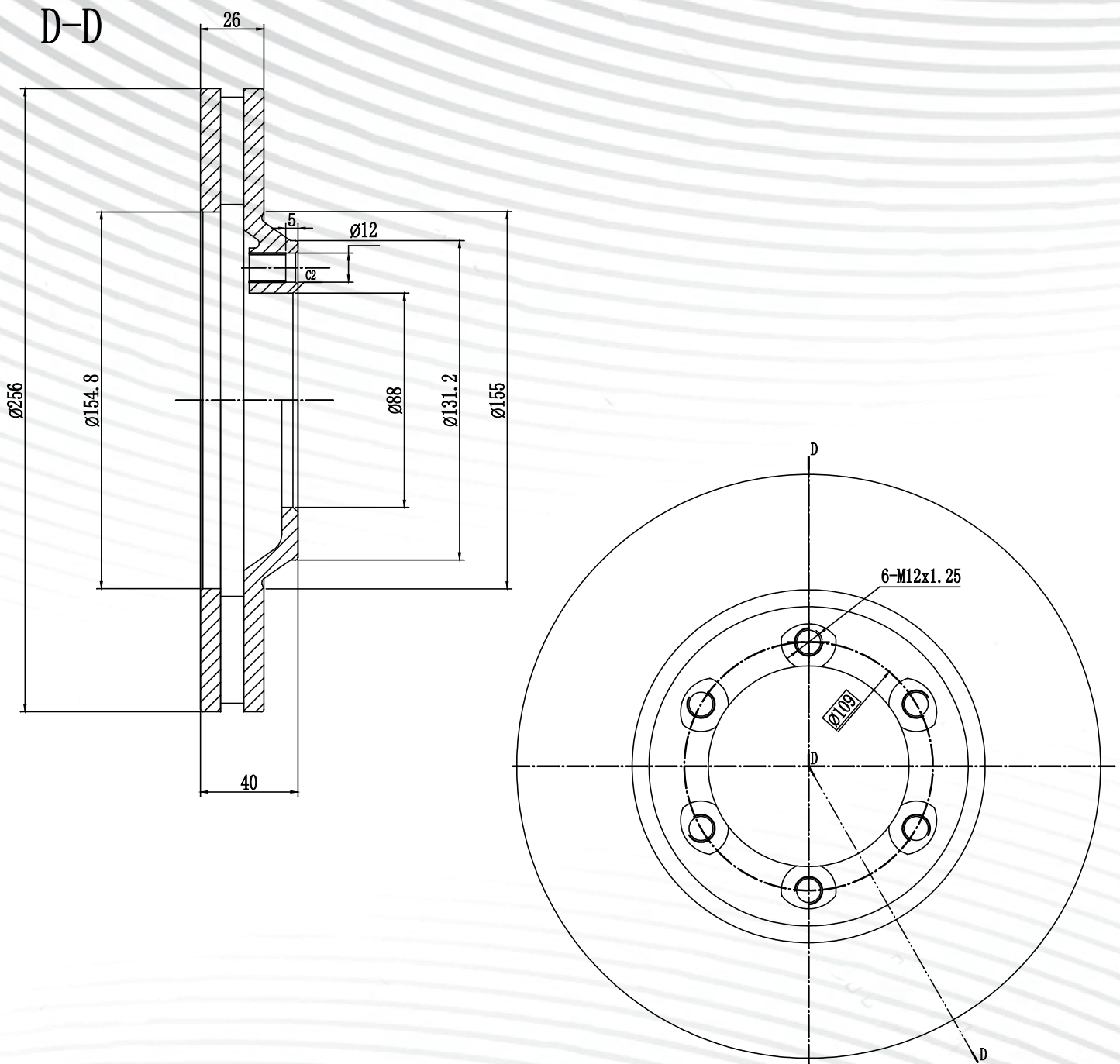

NPC DYNAMIK	FORMULACIÓN	ARMADORA	FREMAX	AÑO	DIÁMETRO	ALTO	ESPESOR	EJE
DNKD1677STH	SMOOTH	CHEVROLET	BD6039	05/09	256 mm	40 mm	26 mm	DELANTERO
APLICACIÓN								
LUV D-MAX 2.4 cc/2.5 cc/3.0 cc 2WD								

DNKD227STH

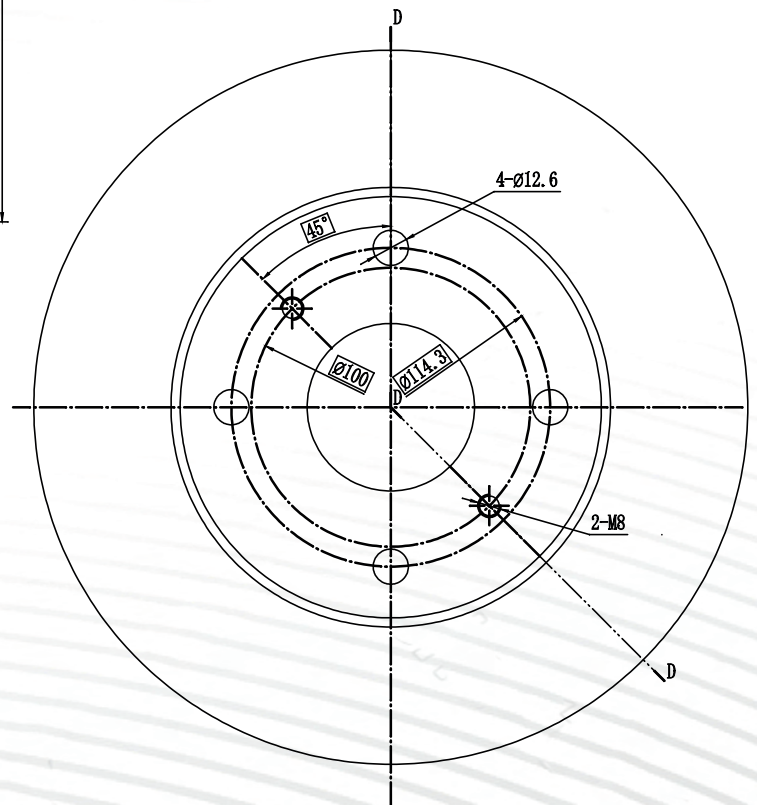
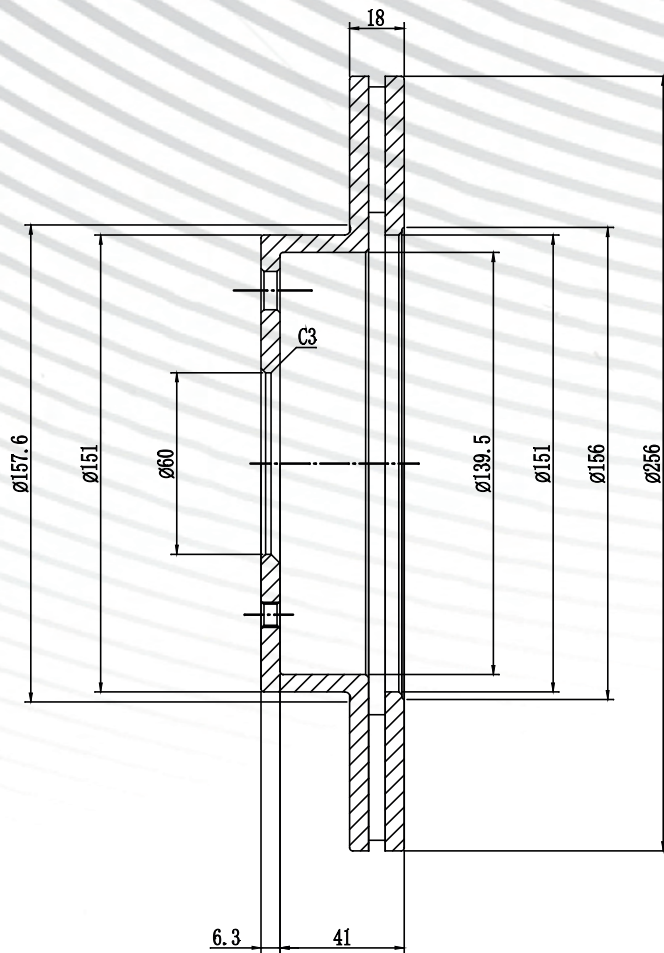

NPC DYNAMIK	FORMULACIÓN	ARMADORA	FREMAX	AÑO	DIÁMETRO	ALTO	ESPESOR	EJE
DNKD227STH	SMOOTH	CHEVROLET	BD3606	12/...	256 mm	47,3 mm	18 mm	DELANTERO
APLICACIÓN								
N300								

DNKD797STH

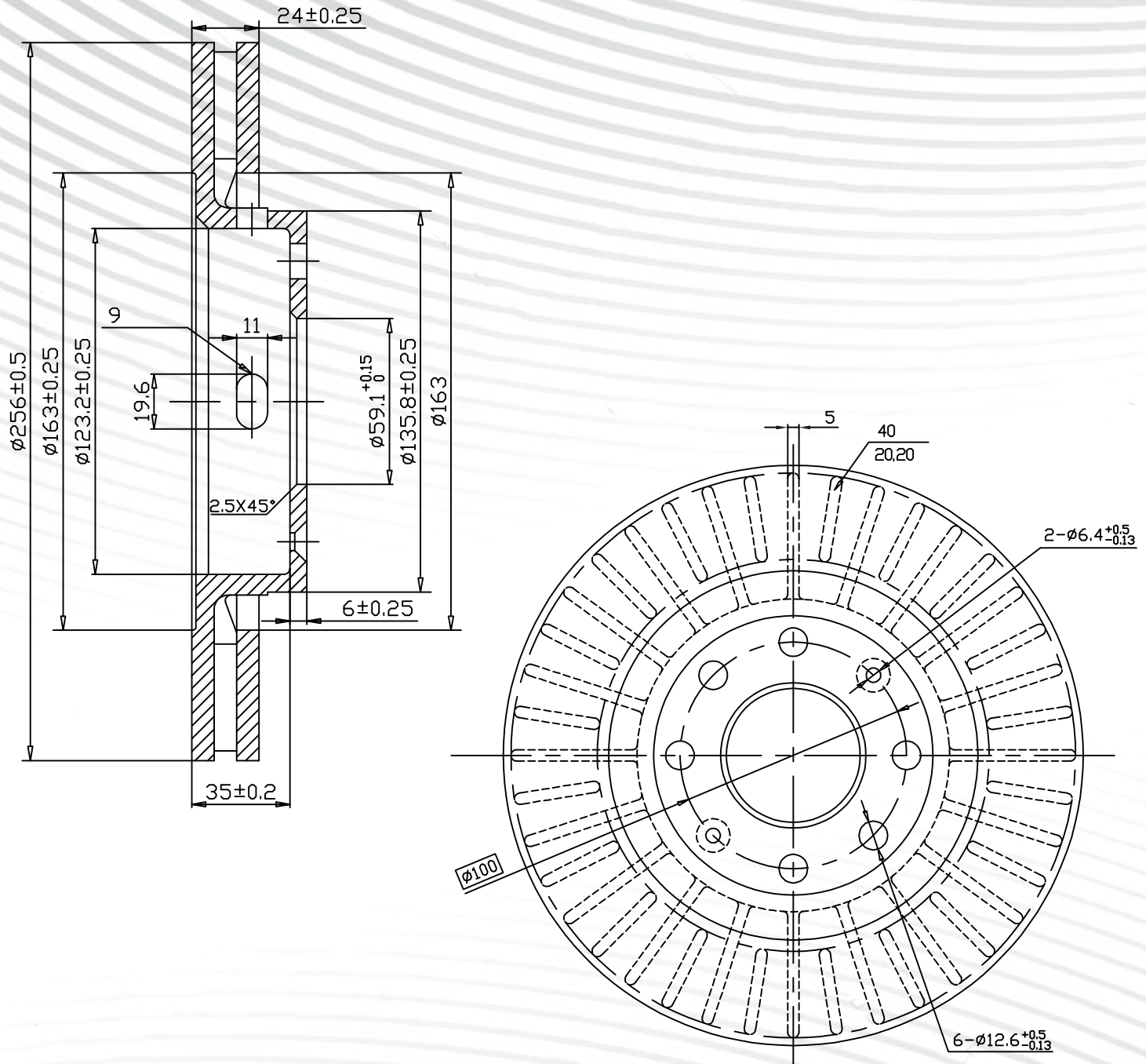

NPC DYNAMIK	FORMULACIÓN	ARMADORA	FREMAX	AÑO	DIÁMETRO	ALTO	ESPESOR	EJE
DNKD797STH	SMOOTH	CHEVROLET	BD4908	TODOS	256 mm	41 mm	24 mm	DELANTERO
APLICACIÓN								
AVEO 1.4cc, 1.5cc, 1.6cc								

DNKD363STH

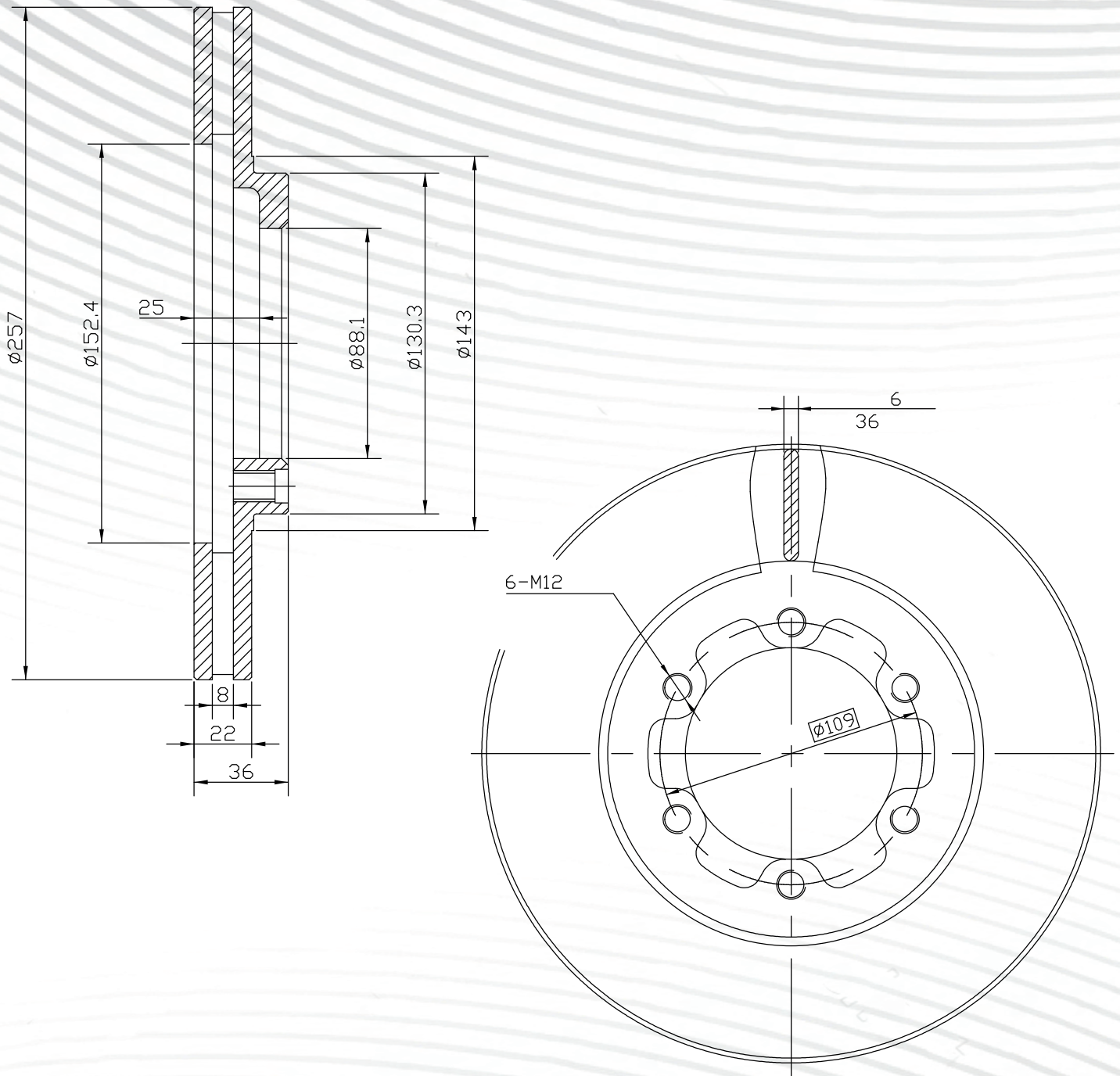

NPC DYNAMIK	FORMULACIÓN	ARMADORA	FREMAX	AÑO	DIÁMETRO	ALTO	ESPESOR	EJE
DNKD363STH	SMOOTH	CHEVROLET	BD2376	TODOS	257 mm	36 mm	22 mm	DELANTERO
APLICACIÓN								
LUV 2.300 / TROOPER / RODEO								

DNKD1036STH

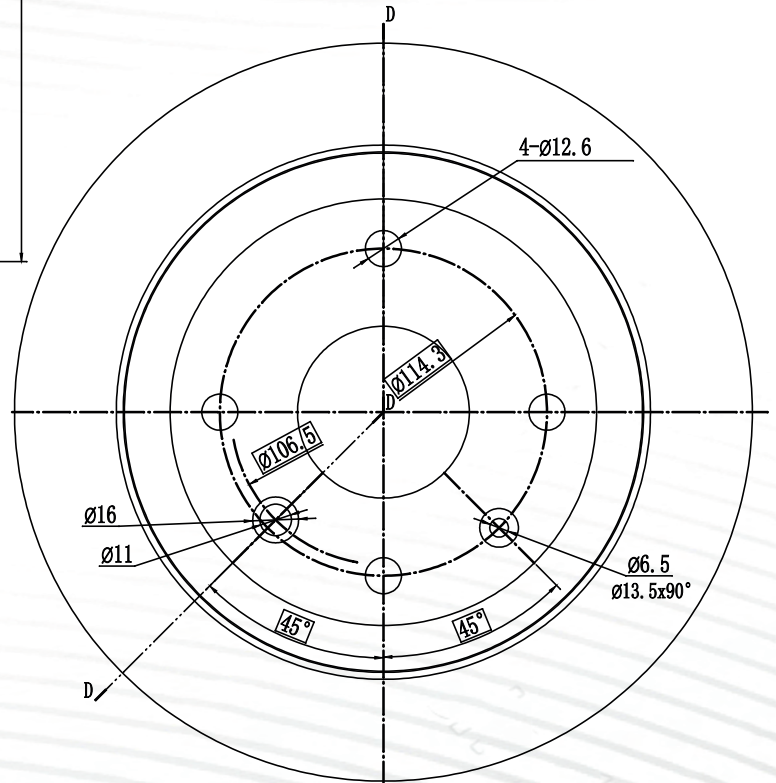
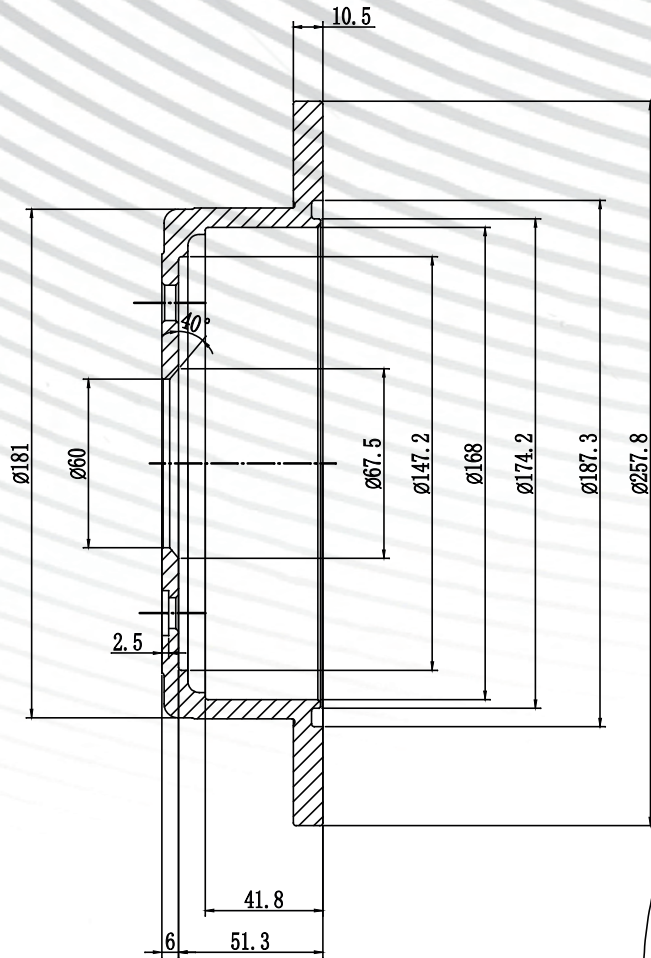

NPC DYNAMIK	FORMULACIÓN	ARMADORA	FREMAX	AÑO	DIÁMETRO	ALTO	ESPESOR	EJE
DNKD1036STH	SMOOTH	CHEVROLET	BD6028	TODOS	257,8 mm	57,3 mm	10,5 mm	TRASERO
APLICACIÓN								
OPTRA 1.4 cc, 1.6 cc, 1.8 cc								

DNKD138STH

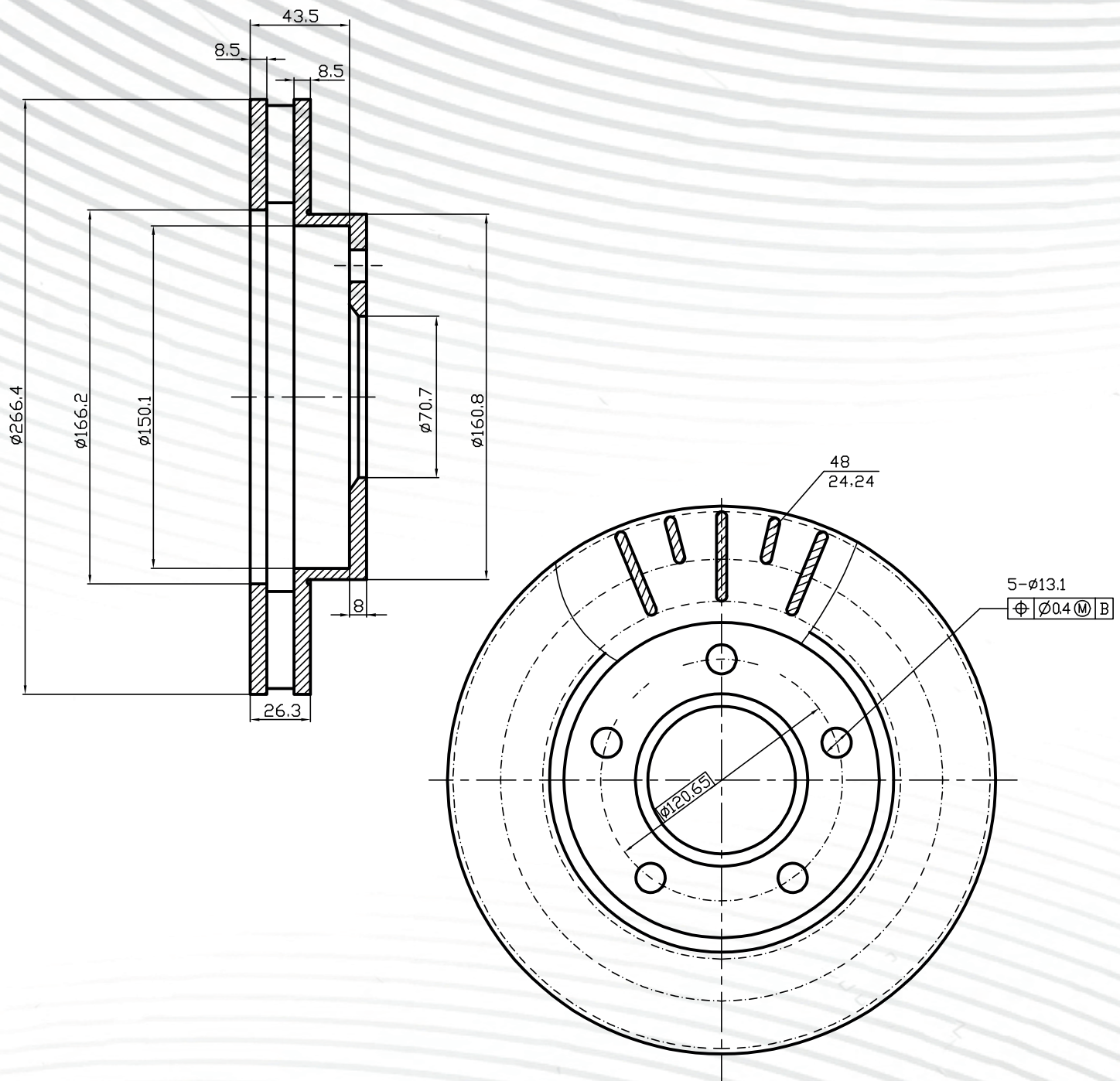

NPC DYNAMIK	FORMULACIÓN	ARMADORA	FREMAX	AÑO	DIÁMETRO	ALTO	ESPESOR	EJE
DNKD138STH	SMOOTH	CHEVROLET	BD6006	92/97	266,4 mm	51,5 mm	26,3 mm	DELANTERO
APLICACIÓN								
BLAZER Y MINIBLAZER 4X4								

DNKD1039STH

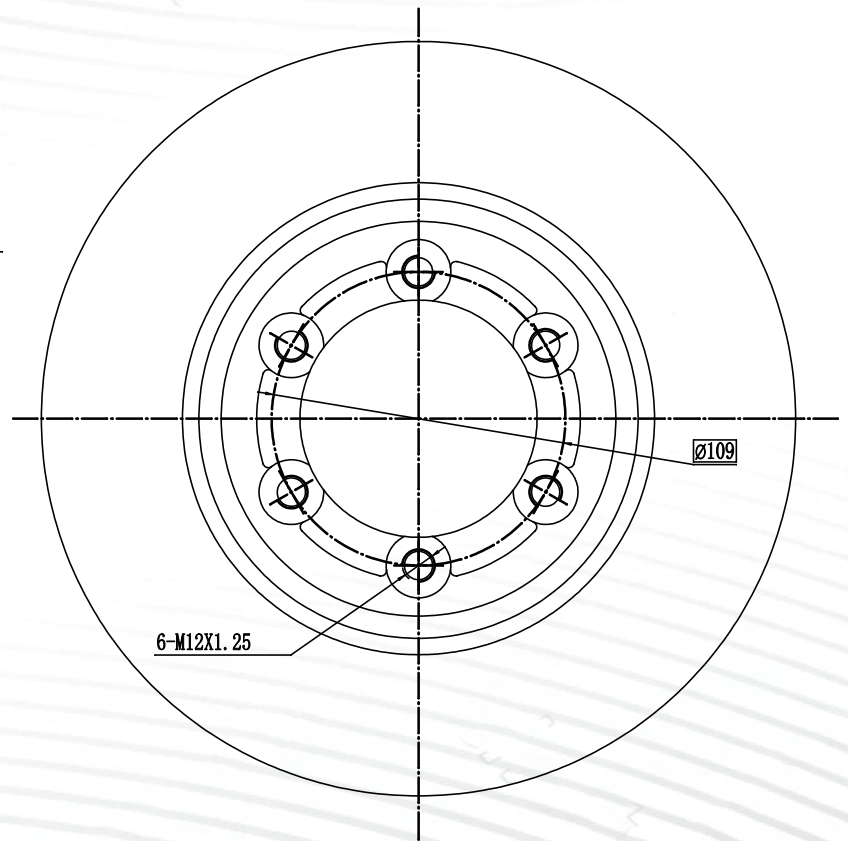
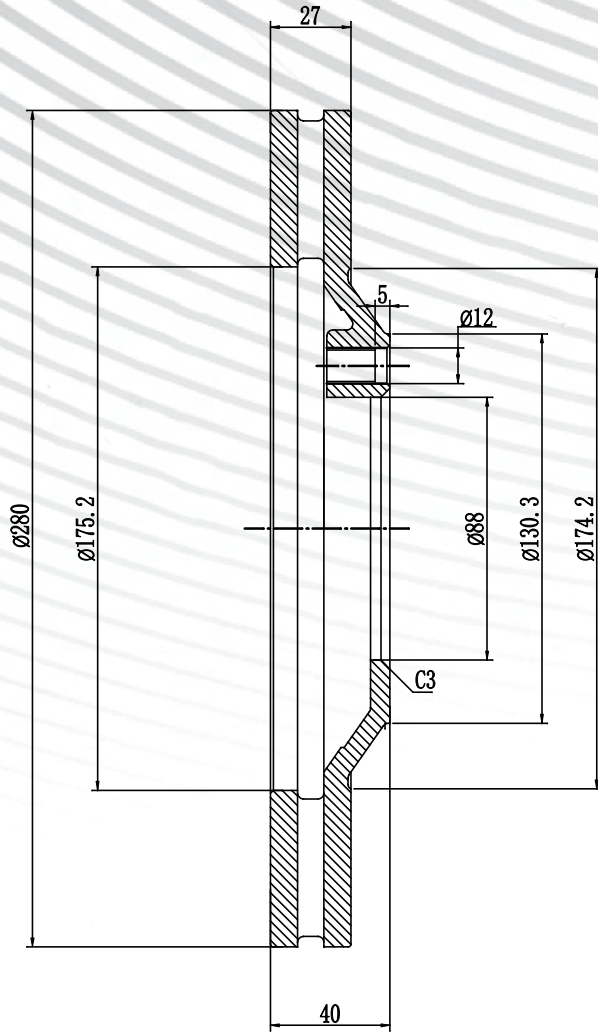

NPC DYNAMIK	FORMULACIÓN	ARMADORA	FREMAX	AÑO	DIÁMETRO	ALTO	ESPESOR	EJE
DNKD1039STH	SMOOTH	CHEVROLET	BD6780	02/...	280 mm	40 mm	27 mm	DELANTERO
APLICACIÓN								
LUV D-MAX 3.0cc 4 WD								

DNKD556GMS

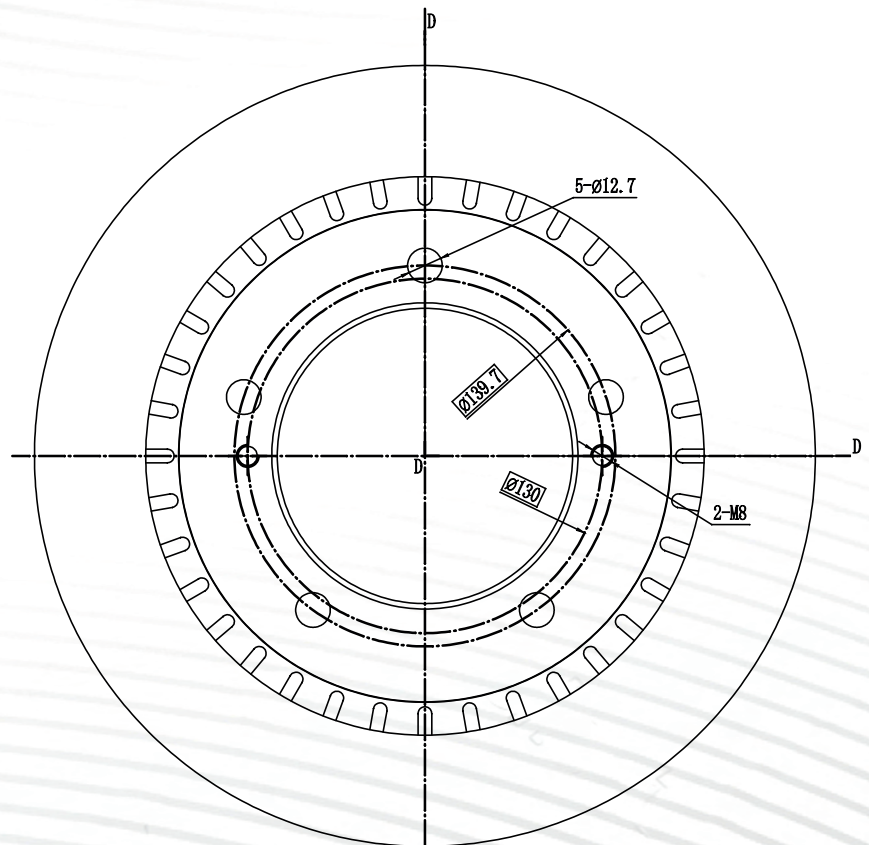
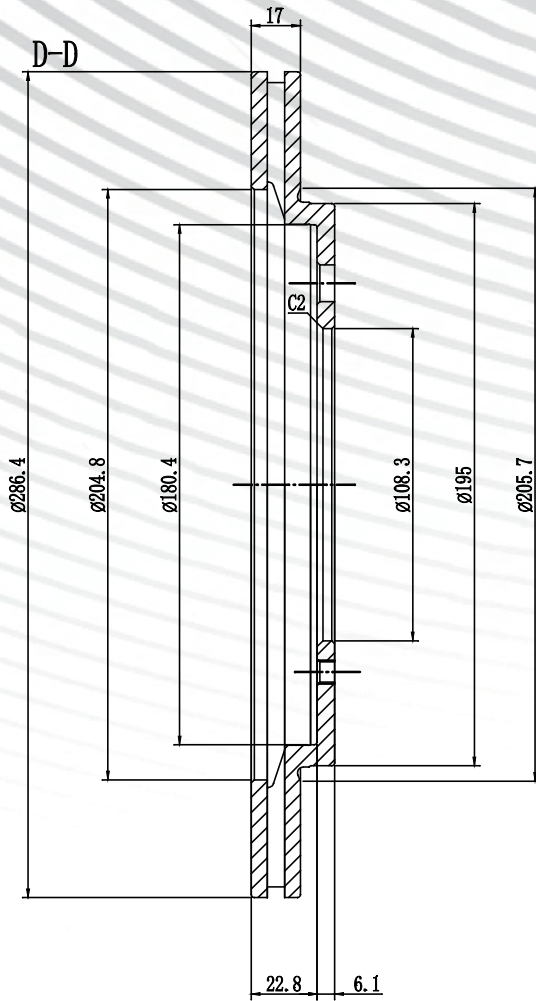

NPC DYNAMIK	FORMULACIÓN	ARMADORA	FREMAX	AÑO	DIÁMETRO	ALTO	ESPESOR	EJE
DNKD556GMS	GEOMET	CHEVROLET	BD2863	00/06	286,4 mm	28,9 mm	17 mm	DELANTERO
APLICACIÓN								
GRAND VITARA XL3 1.6cc, 2.0 cc (3 Y 5 PUERTAS)								

DNKD660STH

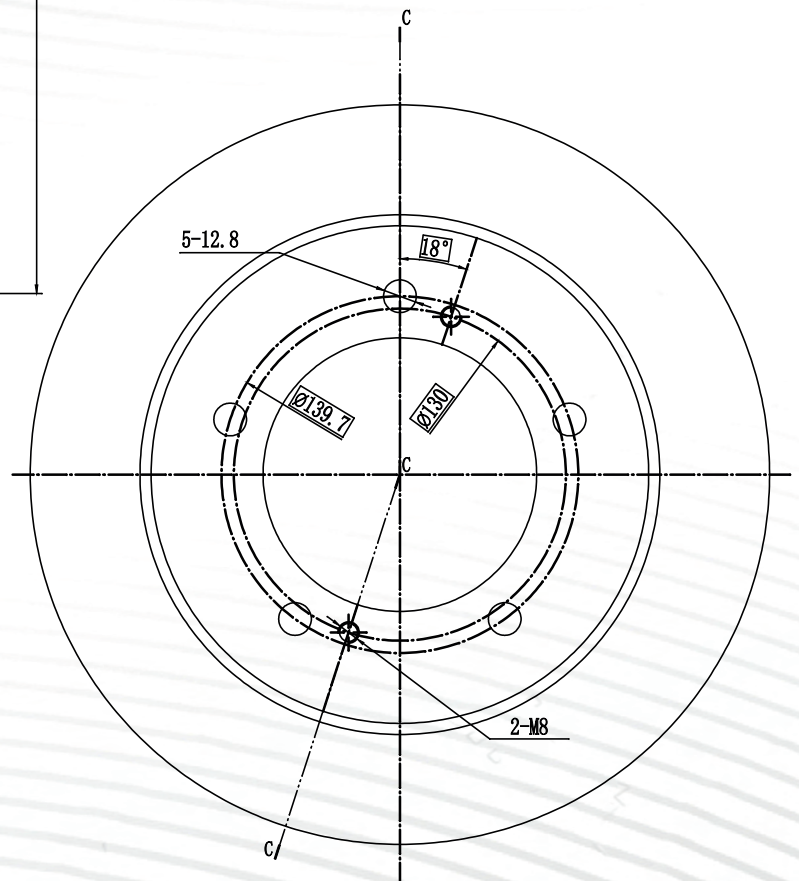
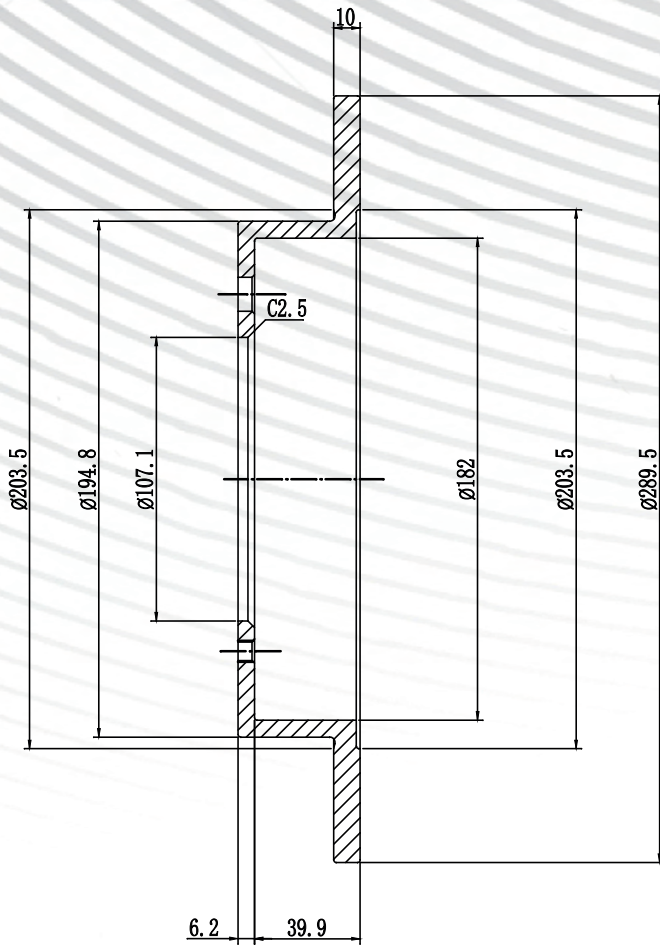

NPC DYNAMIK	FORMULACIÓN	ARMADORA	FREMAX	AÑO	DIÁMETRO	ALTO	ESPESOR	EJE
DNKD660STH	SMOOTH	CHEVROLET	BD6970	90/06	289,5 mm	46,1 mm	10 mm	DELANTERO
APLICACIÓN								
SAMURAI / VITARA 1.6cc (3 PUERTAS) / JIMMY 16valve								

DNKD1467STH

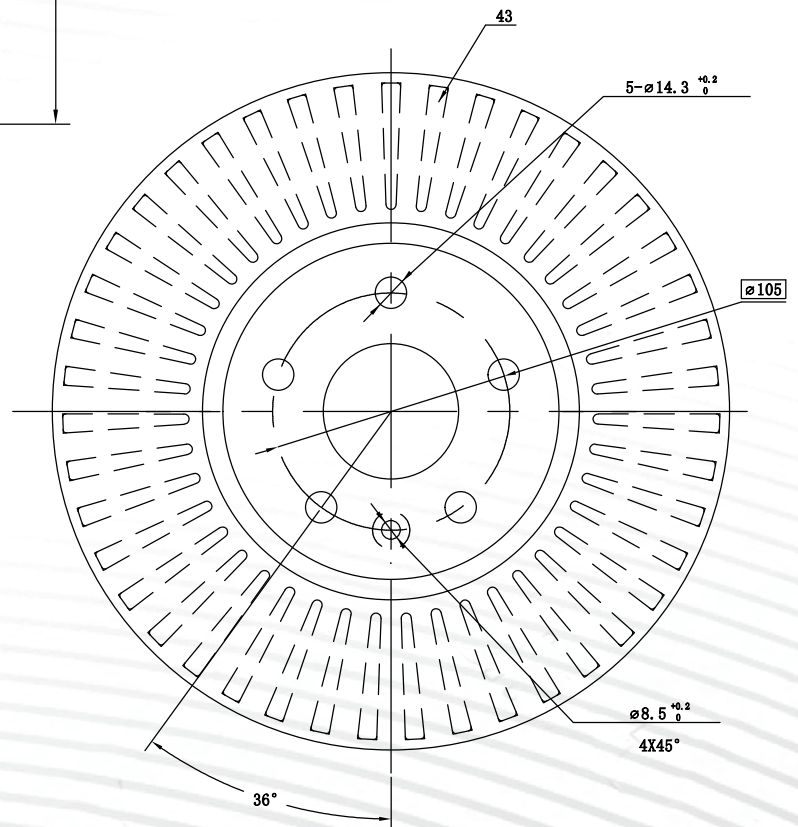
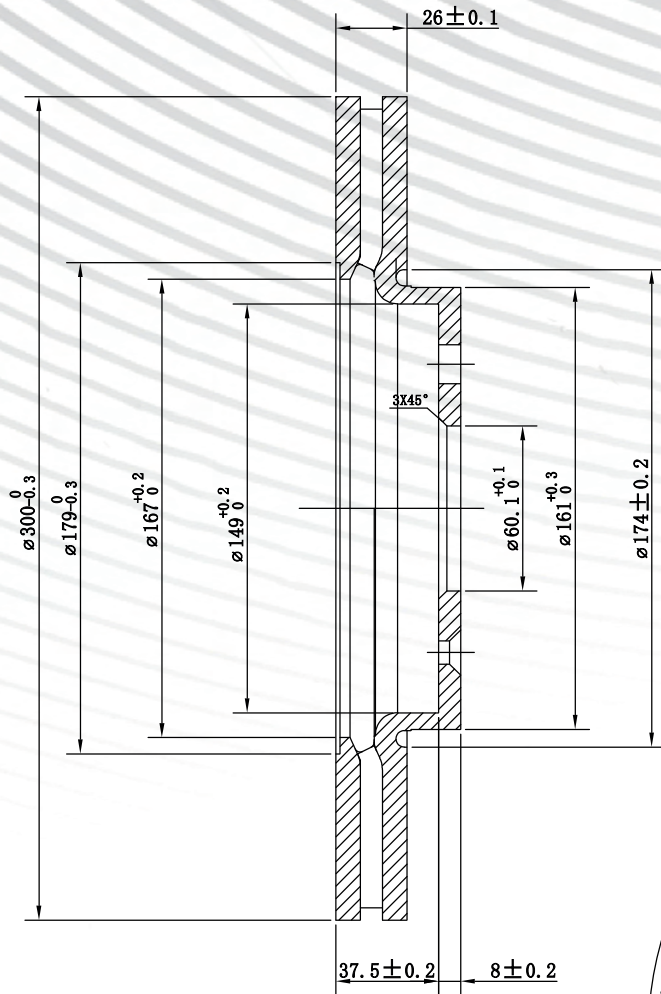

NPC DYNAMIK	FORMULACIÓN	ARMADORA	FREMAX	AÑO	DIÁMETRO	ALTO	ESPESOR	EJE
DNKD1467STH	SMOOTH	CHEVROLET	BD1553	13/...	300 mm	45,5 mm	26 mm	DELANTERO
APLICACIÓN								
TRACKER REF: ORIGINAL 569091								

DNKD1676GMS

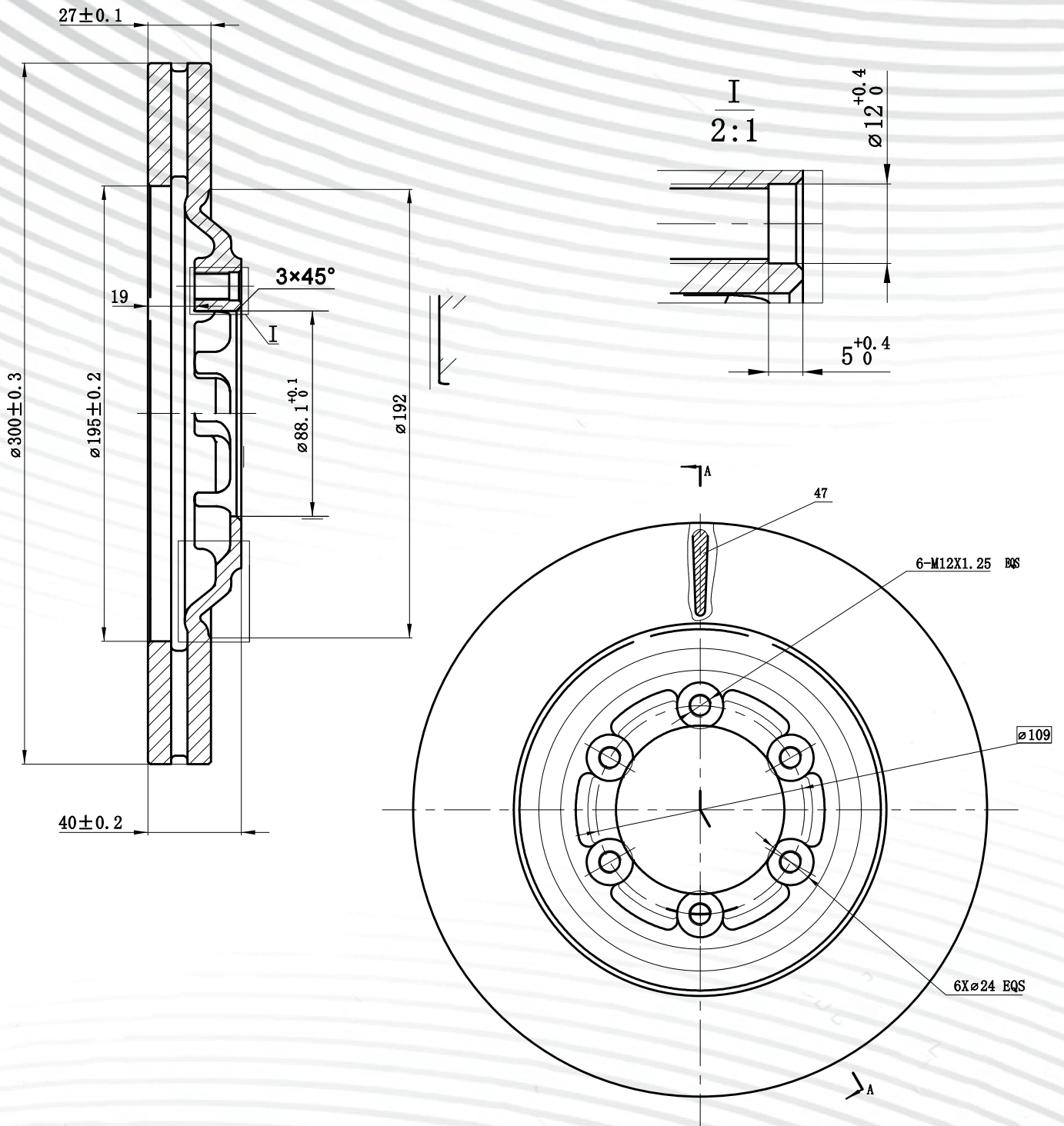

NPC DYNAMIK	FORMULACIÓN	ARMADORA	FREMAX	AÑO	DIÁMETRO	ALTO	ESPESOR	EJE
DNKD1676GMS	GEOMET	CHEVROLET	BD3970	10/... 13/...	300 mm	40 mm	27 mm	DELANTERO
APLICACIÓN								
ISUZU - LUV NEW D-MAX (I190) 3.0cc TRAILBLAZER 2.8cc 3.0cc								

DNKD378STH

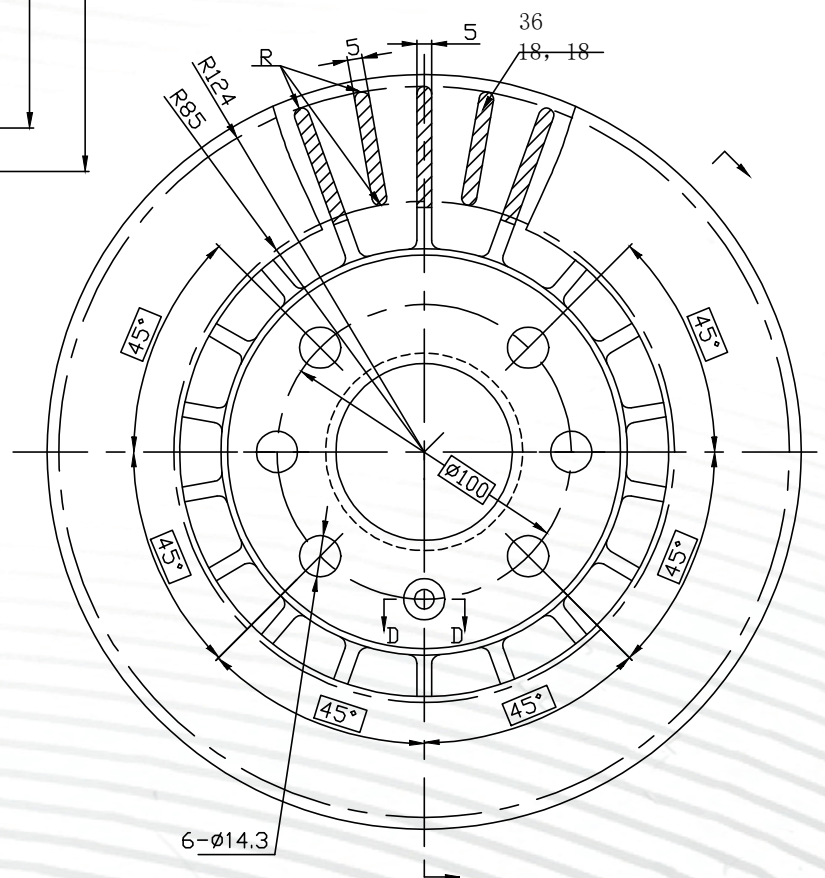
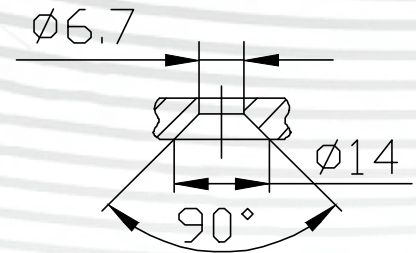
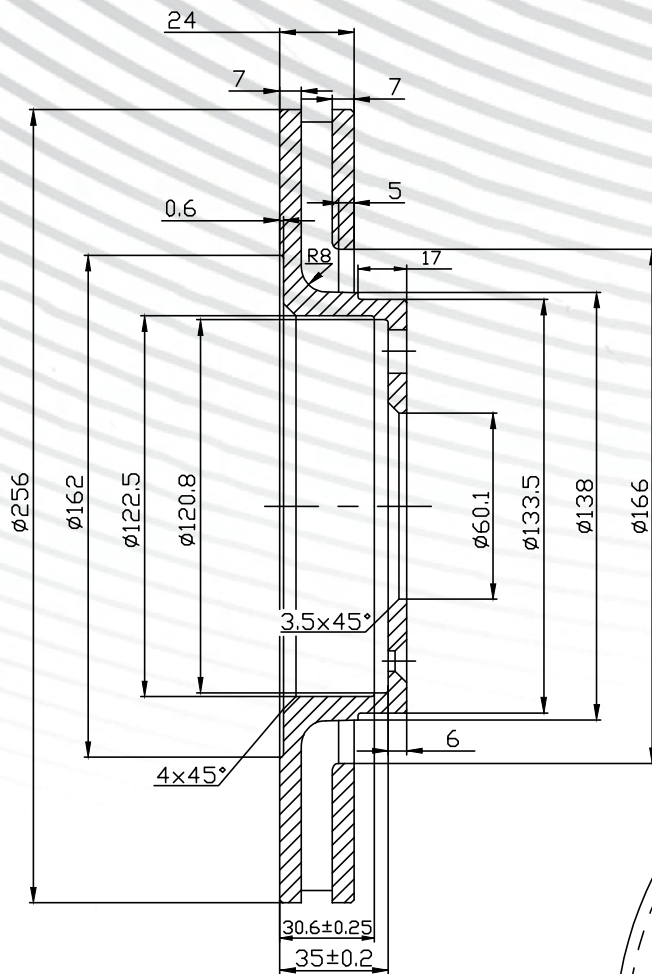

NPC DYNAMIK	FORMULACIÓN	ARMADORA	FREMAX	AÑO	DIÁMETRO	ALTO	ESPESOR	EJE
DNKD378STH	SMOOTH	DAEWOO	BD9042	94/98 92/95	256 mm	41 mm	24 mm	DELANTERO
APLICACIÓN								
CIELO GLX 1.5cc 16valve DOHC ESPERO 1.8cc, 2.0cc 16valve								

DNKD350STH

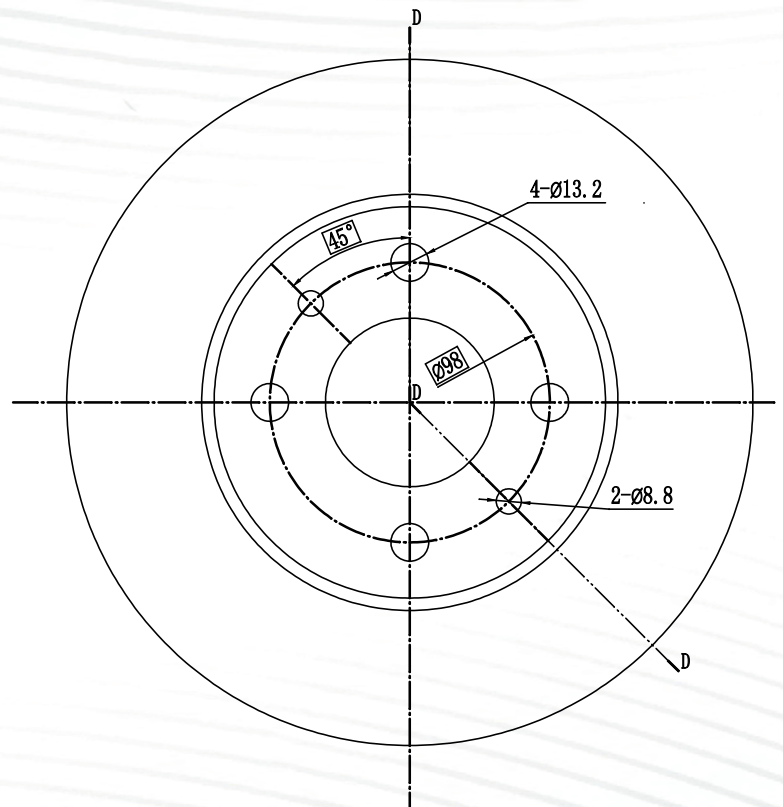
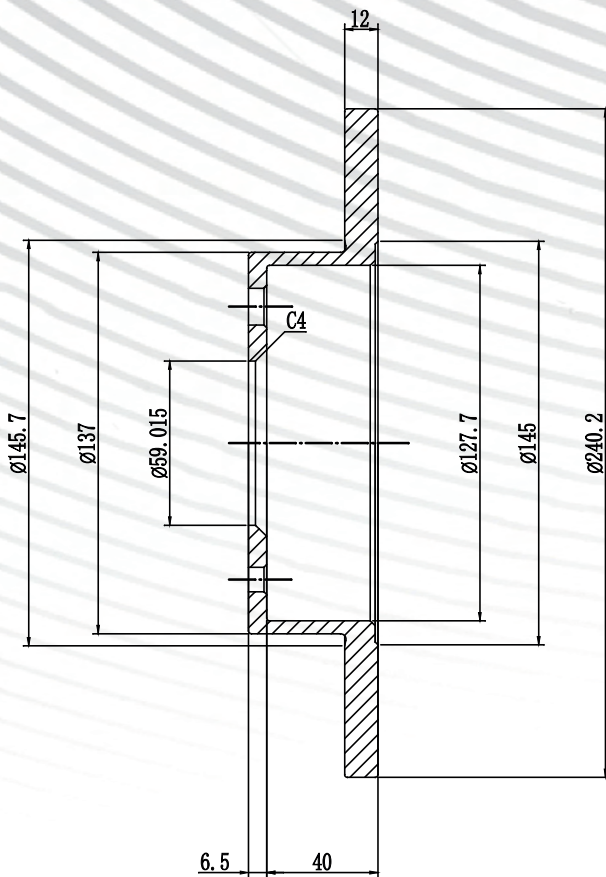

NPC DYNAMIK	FORMULACIÓN	ARMADORA	FREMAX	AÑO	DIÁMETRO	ALTO	ESPESOR	EJE
DNKD350STH	SMOOTH	FIAT	BD1815	94/97 90/97 90/97 96/99 96/13	240,2 mm	46,5 mm	12 mm	DELANTERO
APLICACIÓN								
UNO MILLE 1.0 UNO SCR 1.3, 705 1.3, CSL 1.6 PREMIO CS 1.3, TAXI 1.5, CSL 1.6 PALIO, SIENA 1.3, 1.6 SIENA 1.4 PARTICULAR REF:OEM:5961814								

DNKD1563STH

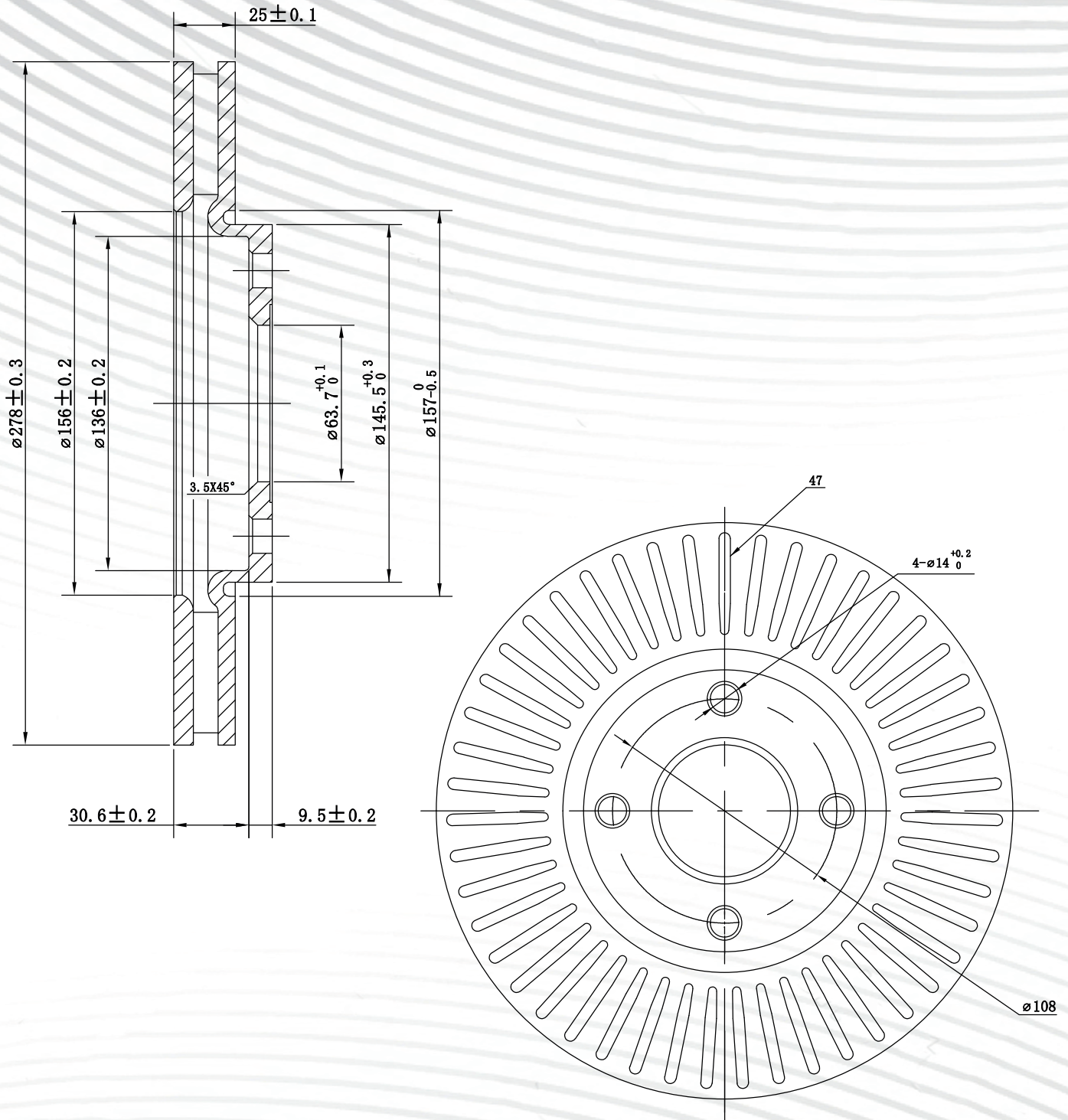

NPC DYNAMIK	FORMULACIÓN	ARMADORA	FREMAX	AÑO	DIÁMETRO	ALTO	ESPESOR	EJE
DNKD1563STH	SMOOTH	FORD	BD5212	13/...	278 mm	40,1 mm	25 mm	DELANTERO
APLICACIÓN								
ECOSPORT 4X2 / 4X4								

DNKD1044STH

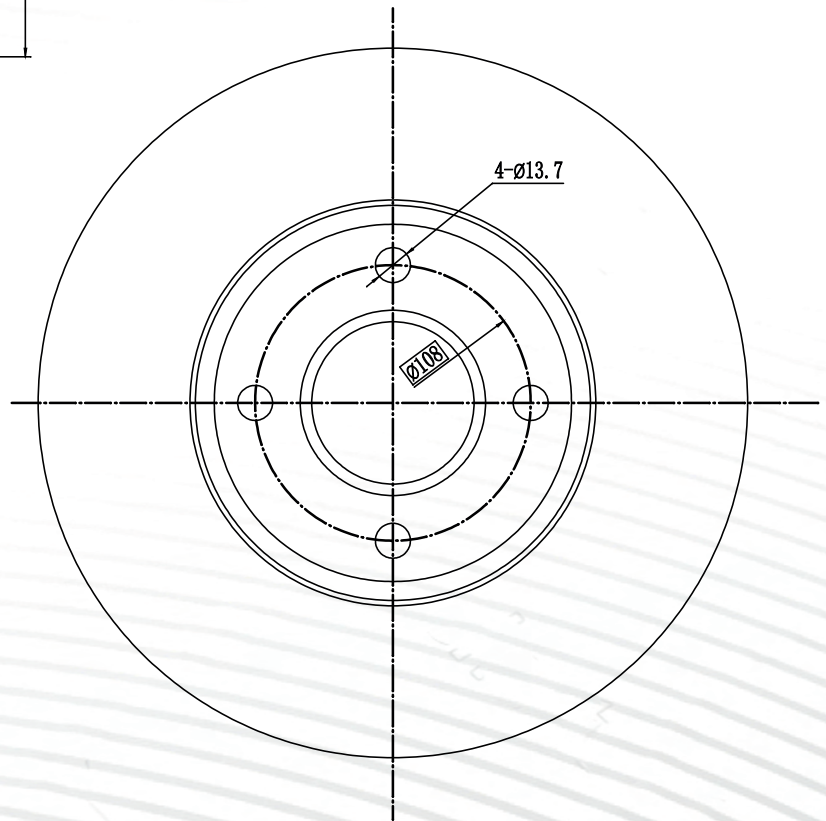
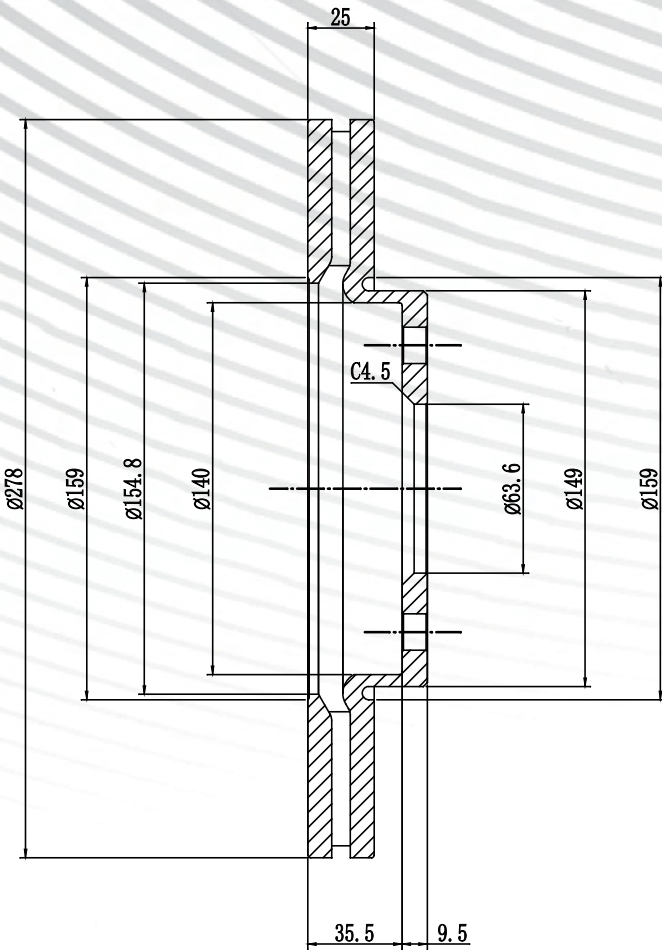

NPC DYNAMIK	FORMULACIÓN	ARMADORA	FREMAX	AÑO	DIÁMETRO	ALTO	ESPESOR	EJE
DNKD1044STH	SMOOTH	FORD	BD5211	07/...	278 mm	45 mm	25 mm	DELANTERO
APLICACIÓN								
ECOSPORT 2.0cc 16V (caja automática) / 4X2								

DNKD1573GMS

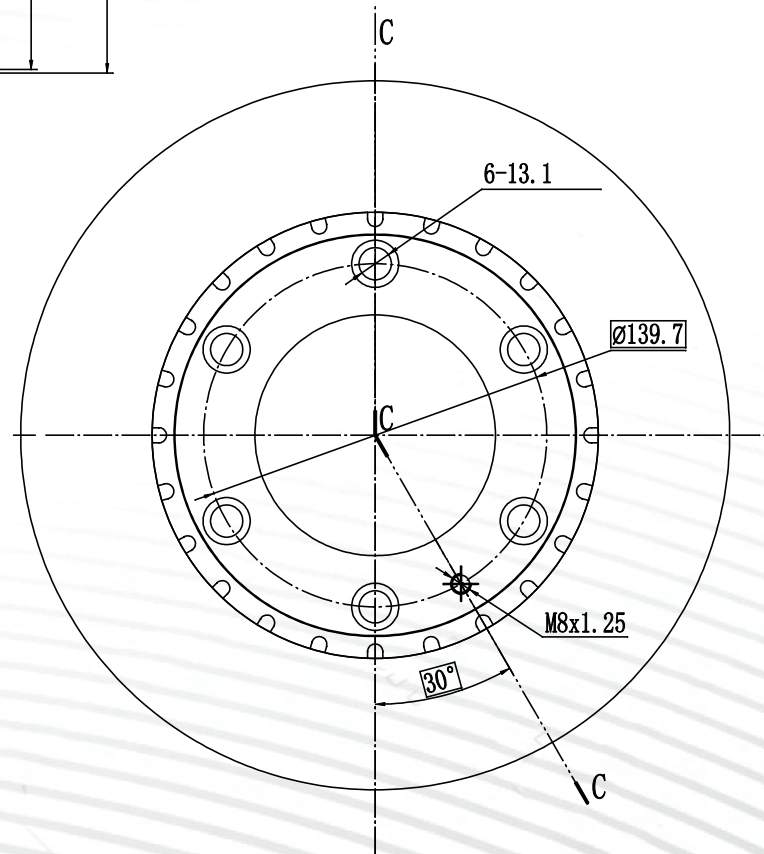
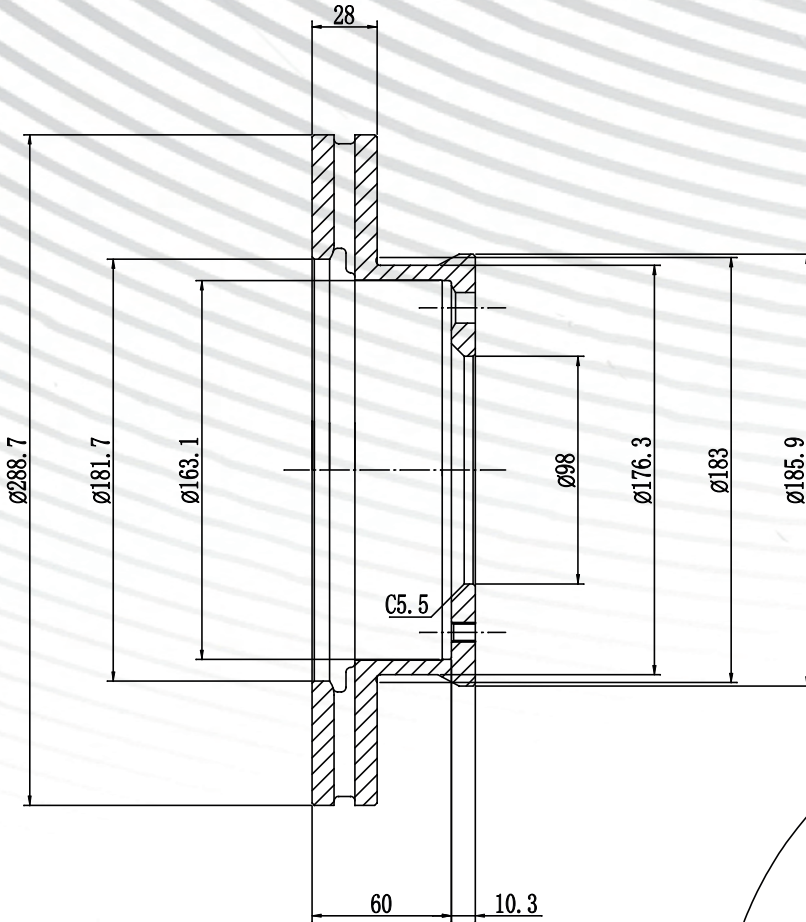

NPC DYNAMIK	FORMULACIÓN	ARMADORA	FREMAX	AÑO	DIÁMETRO	ALTO	ESPEJOR	EJE
DNKD1573GMS	GEOMET	FORD	BD6032	08/...	288,7 mm	70,3 mm	28 mm	DELANTERO
APLICACIÓN								
NUEVA RANGER 2.2cc / 2.5cc / 2.6 cc 4X2-4X4								

DNKD1142STH

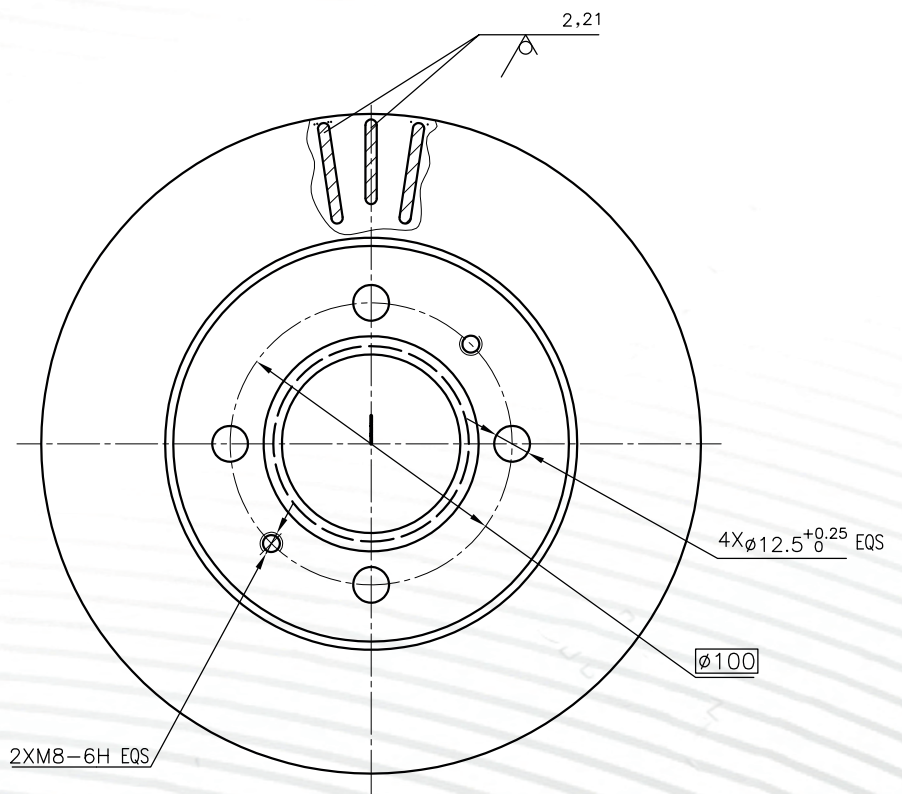
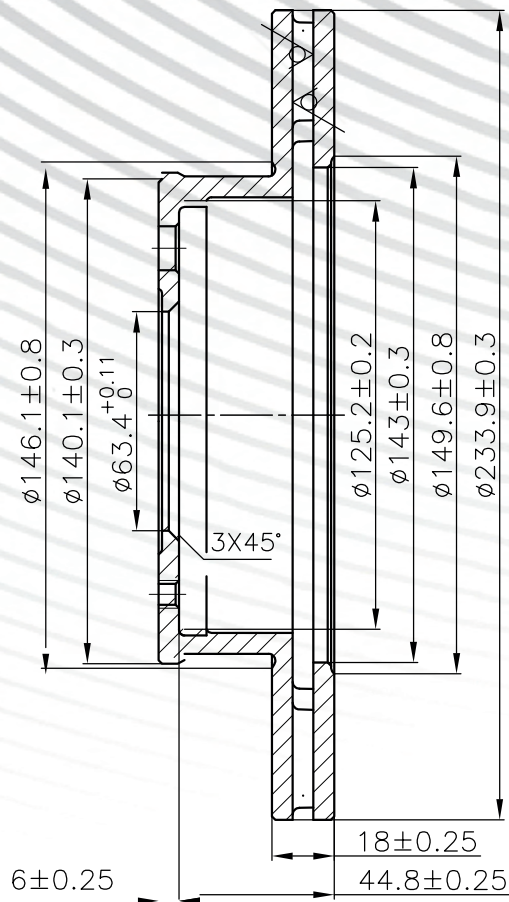

NPC DYNAMIK	FORMULACIÓN	ARMADORA	FREMAX	AÑO	DIÁMETRO	ALTO	ESPESOR	EJE
DNKD1142STH	SMOOTH	HYUNDAI	BD0550	01/08	233,9 mm	50,8 mm	18 mm	DELANTERO
APLICACIÓN								
ATOS 1.0cc / PRIME 1.0cc / SANTRO 1.0cc, 1.1cc TAXI								

DNKD1684STH

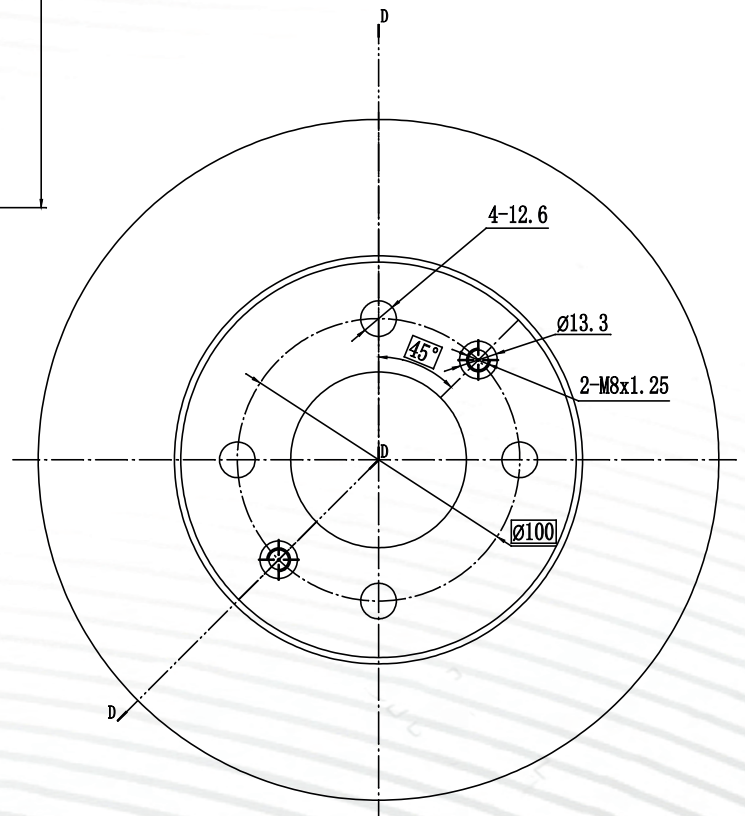
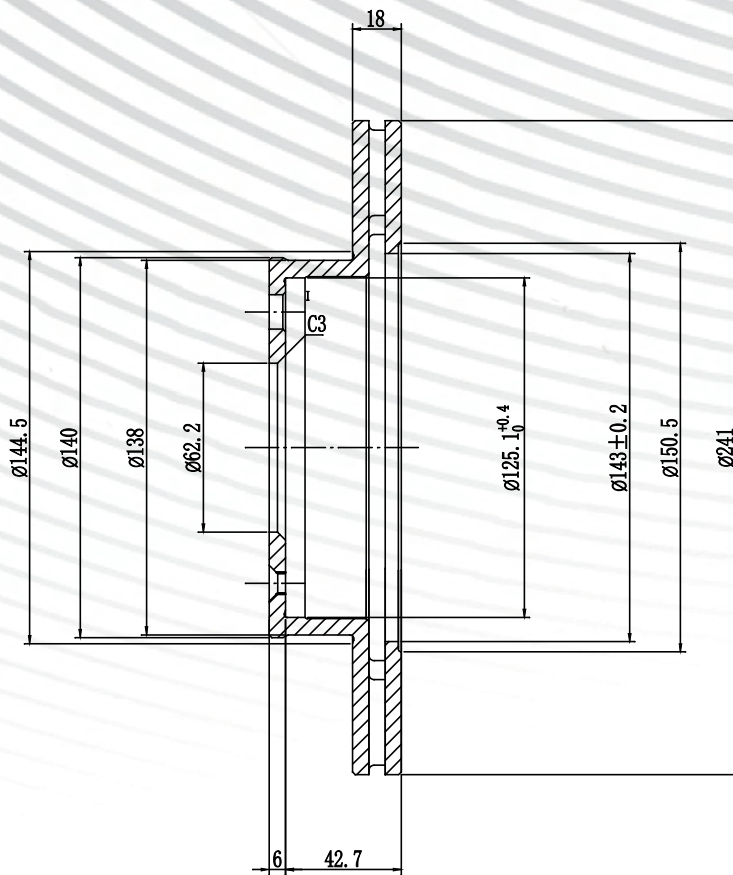

NPC DYNAMIK	FORMULACIÓN	ARMADORA	FREMAX	AÑO	DIÁMETRO	ALTO	ESPESOR	EJE
DNKD1684STH	SMOOTH	HYUNDAI	BD7500	08/...	241 mm	48,7 mm	18 mm	DELANTERO
APLICACIÓN								
i10 1.1cc 12 valve								

DNKD497STH

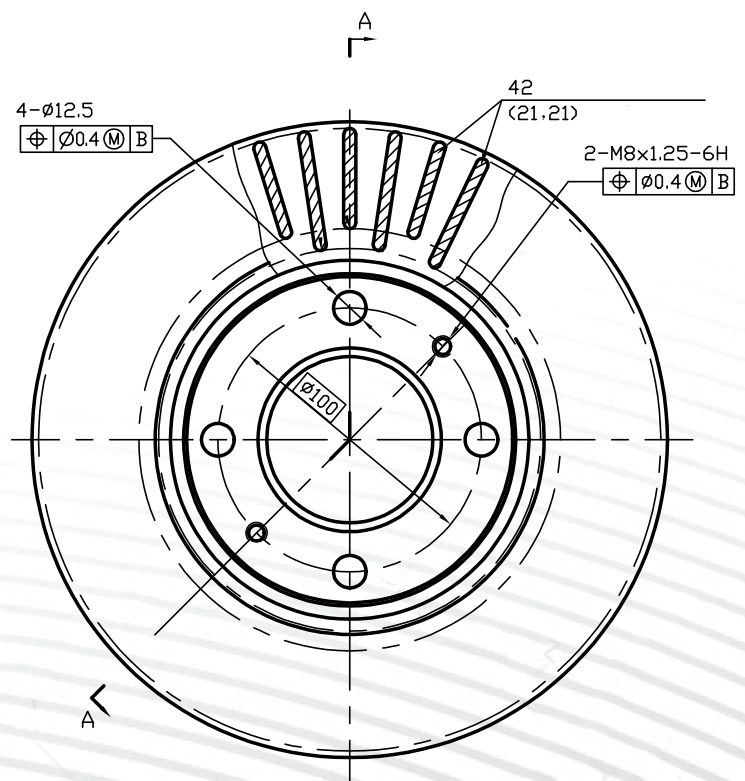
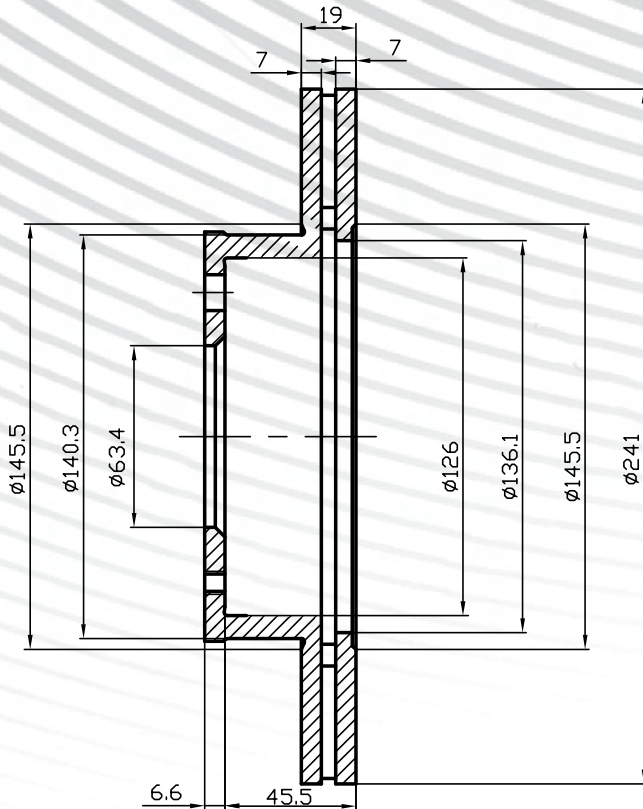

NPC DYNAMIK	FORMULACIÓN	ARMADORA	FREMAX	AÑO	DIÁMETRO	ALTO	ESPESOR	EJE
DNKD497STH	SMOOTH	HYUNDAI	BD1008	99/06	241 mm	52,1 mm	19 mm	DELANTERO
APLICACIÓN								
VERNA O.E.M. # 5171225060 - 5171225061								

DNKD497GMS

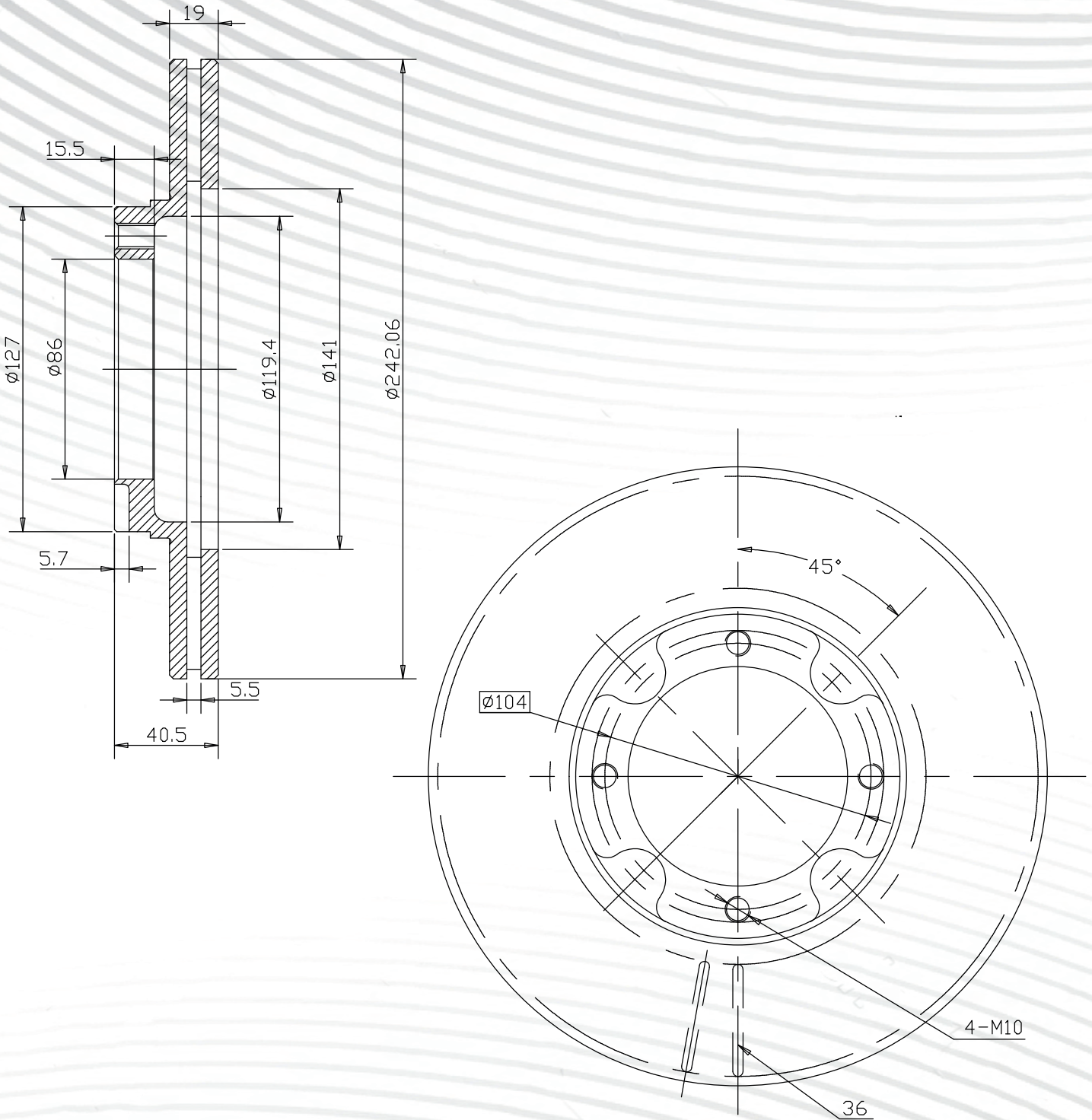

NPC DYNAMIK	FORMULACIÓN	ARMADORA	FREMAX	AÑO	DIÁMETRO	ALTO	ESPESOR	EJE
DNKD497GMS	GEOMET	HYUNDAI	BD2135	TODOS	242,1 mm	40,5 mm	19 mm	DELANTERO
APLICACIÓN								
ACCENT								

DNKD1935STH

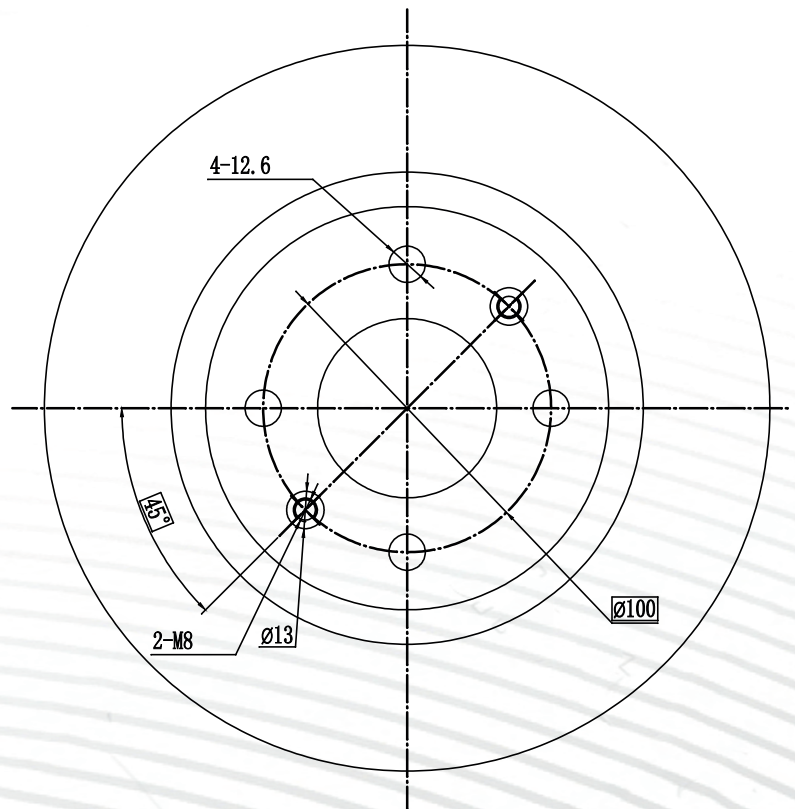
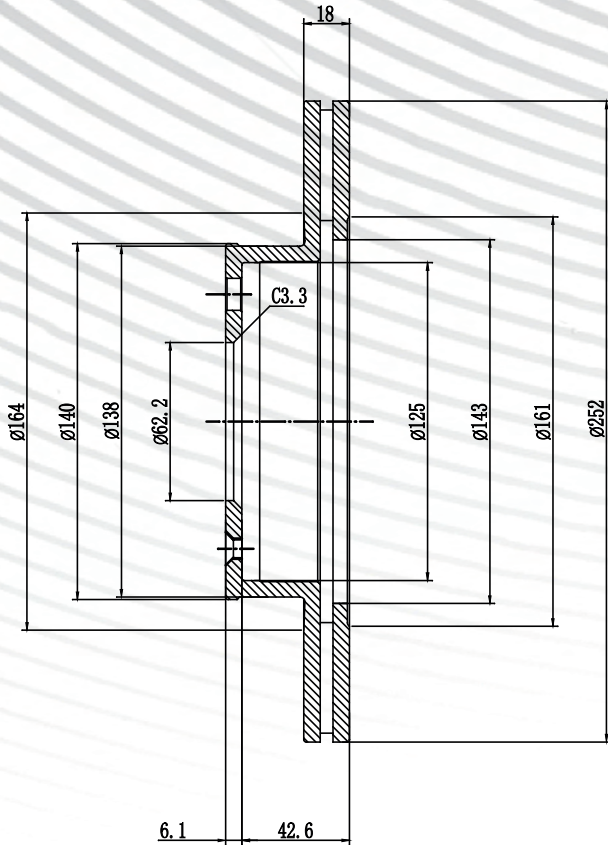

NPC DYNAMIK	FORMULACIÓN	ARMADORA	FREMAX	AÑO	DIÁMETRO	ALTO	ESPESOR	EJE
DNKD1935STH	SMOOTH	HYUNDAI	BD7510	13/...	252 mm	48,7 mm	18 mm	DELANTERO
APLICACIÓN								
GRAND I-10 TAXI REF: ORIGINAL 517120X700								

DNKD1156GMS

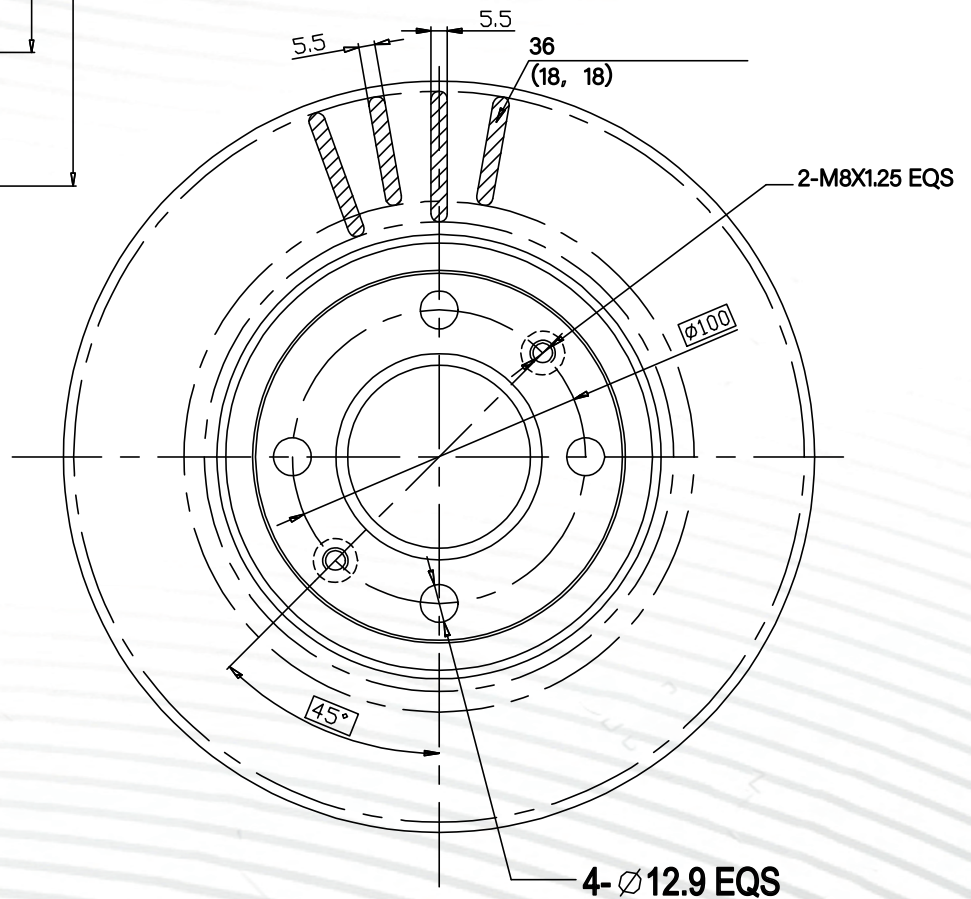
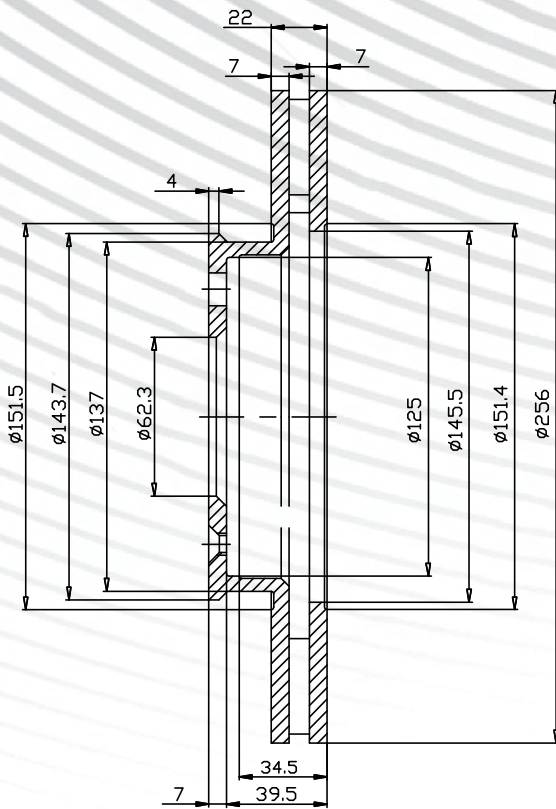

NPC DYNAMIK	FORMULACIÓN	ARMADORA	FREMAX	AÑO	DIÁMETRO	ALTO	ESPEJOR	EJE
DNKD1156GMS	GEOMET	HYUNDAI	BD5101	05/...	256 mm	46,5 mm	22 mm	DELANTERO
APLICACIÓN								
ACCENT VISION 1.4cc Y 1.6cc 16 valve								

DNKD1157GMS

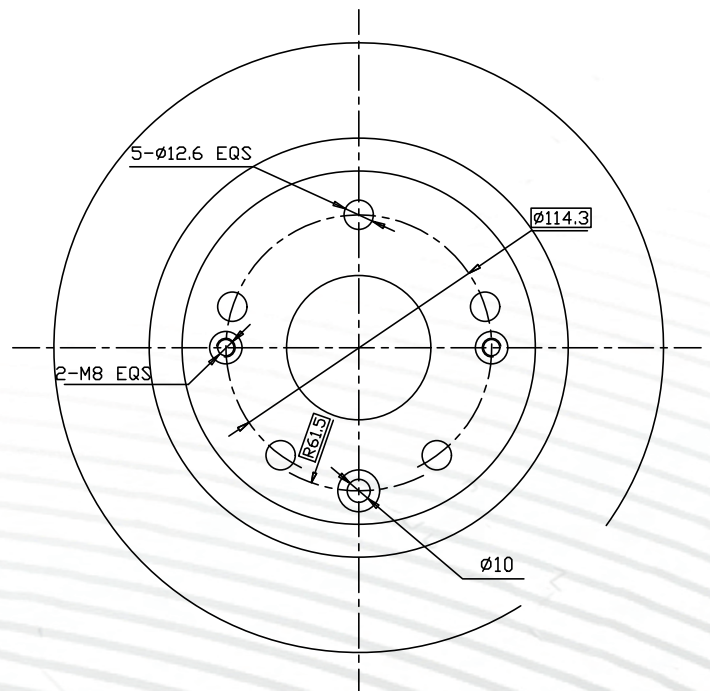
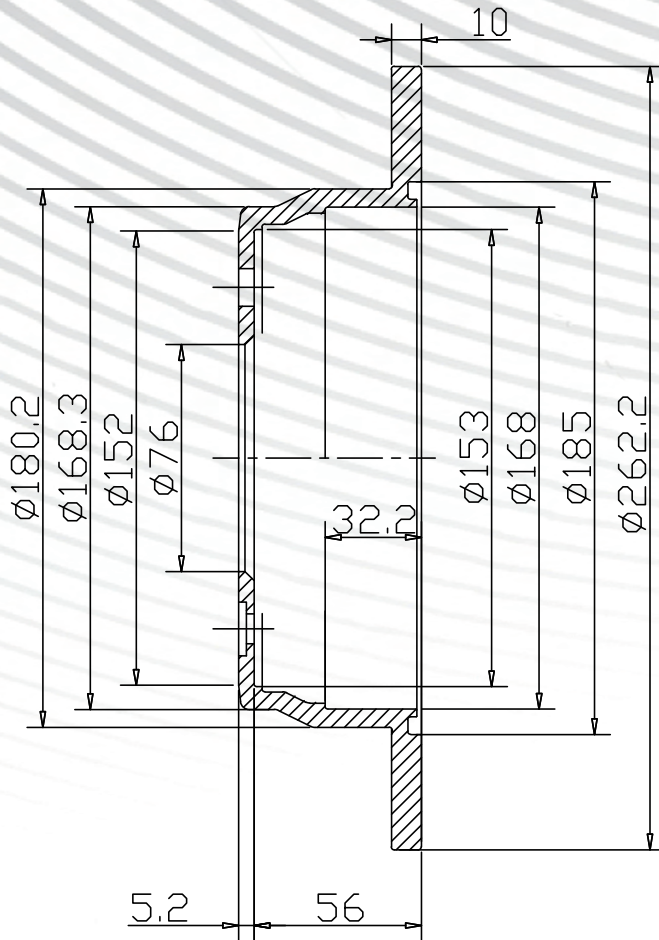

NPC DYNAMIK	FORMULACIÓN	ARMADORA	FREMAX	AÑO	DIÁMETRO	ALTO	ESPESOR	EJE
DNKD1157GMS	GEOMET	HYUNDAI	BD0581	10/...	262,2 mm	61,2 mm	10 mm	TRASERO
APLICACIÓN								
i30 GLS 2.0cc / TUCSON IX 35								

DNKD1447STH

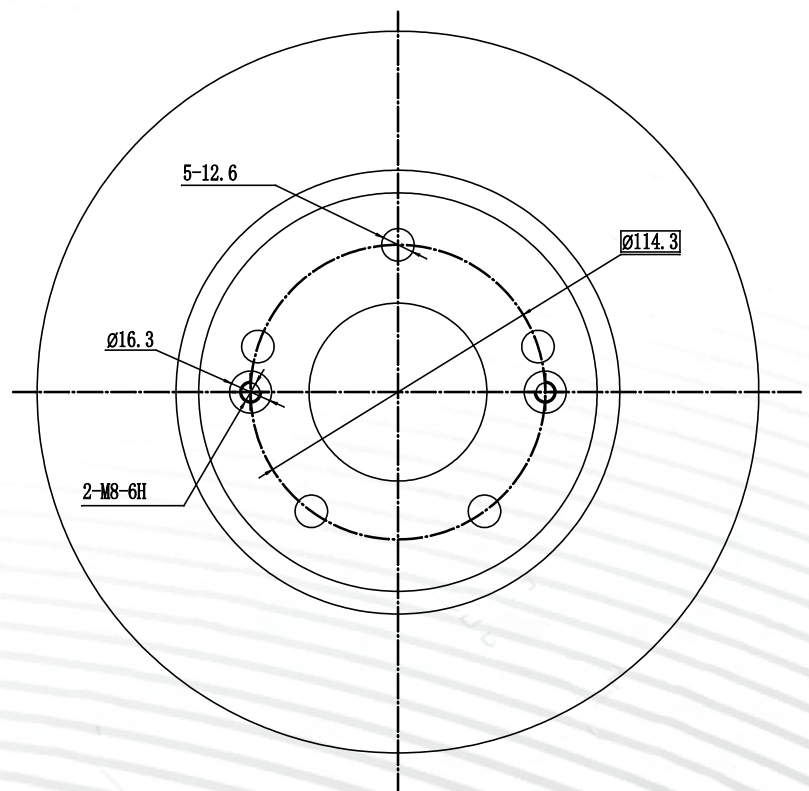
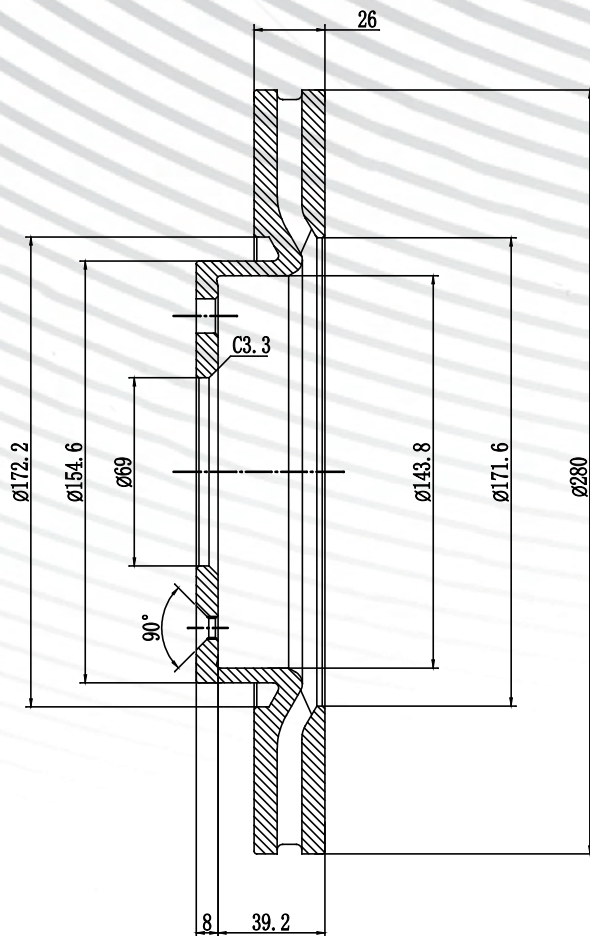

NPC DYNAMIK	FORMULACIÓN	ARMADORA	FREMAX	AÑO	DIÁMETRO	ALTO	ESPESOR	EJE
DNKD1447STH	SMOOTH	HYUNDAI	BD5171	TODOS 10/	280 mm	47,2 mm	26 mm	DELANTERO
APLICACIÓN								
TUCSON 2.0cc, 2.7cc TIBURÓN 2.0cc i30 2.0cc TUCSON Ix35 TUCSON IX35 4X2								

DNKD1593STH

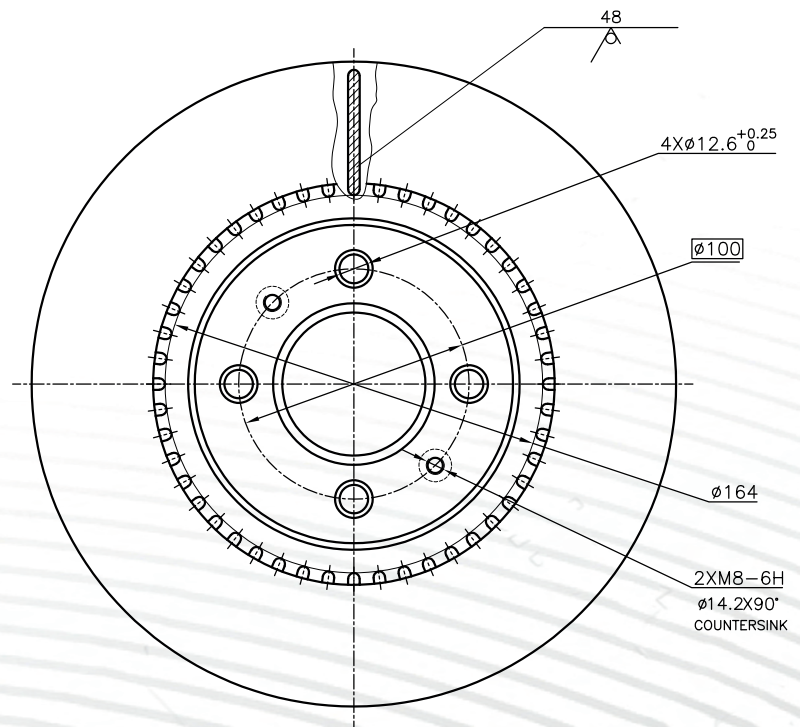
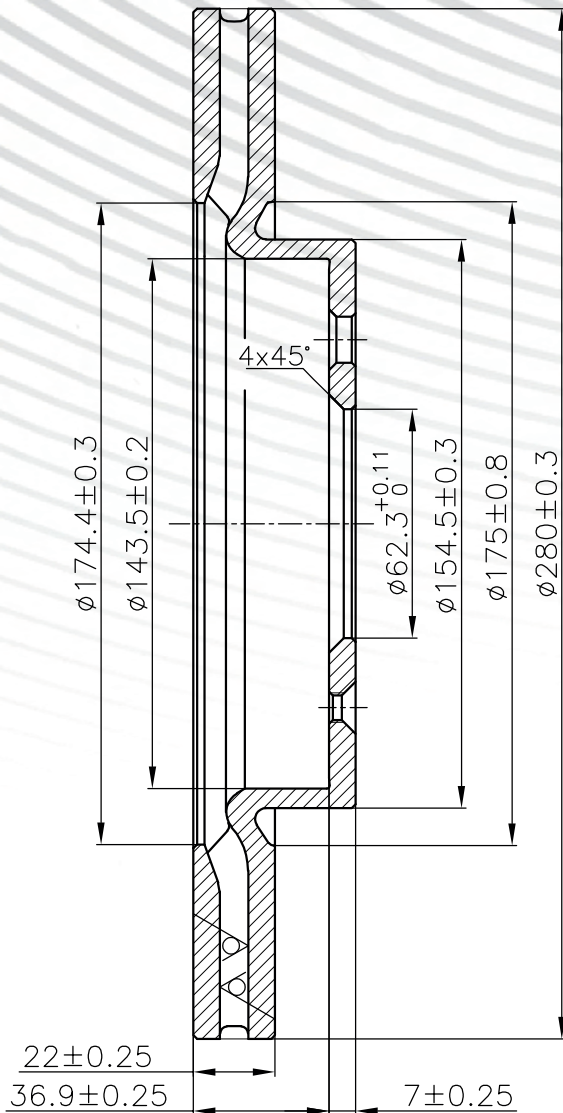

NPC DYNAMIK	FORMULACIÓN	ARMADORA	FREMAX	AÑO	DIÁMETRO	ALTO	ESPEJOR	EJE
DNKD1593STH	SMOOTH	HYUNDAI	BD5207	12/... 16/...	280 mm	43,9 mm	22 mm	DELANTERO
APLICACIÓN								
i25 1.4cc, 1.6cc 120 1.4cc ADVANCE								

DNKE465STH

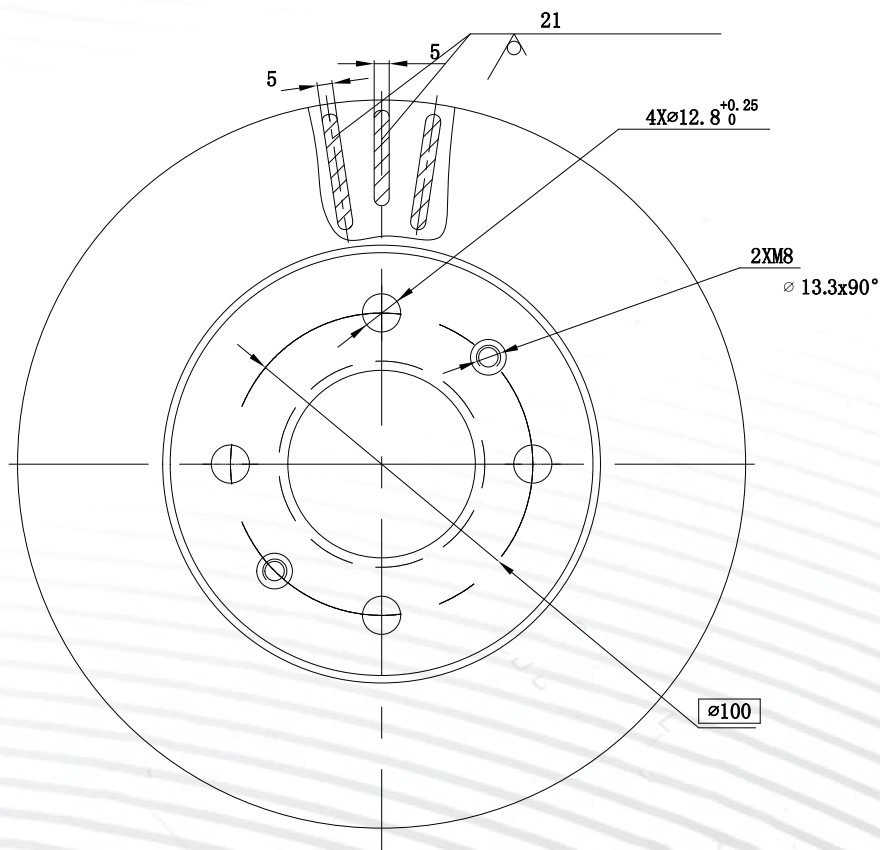
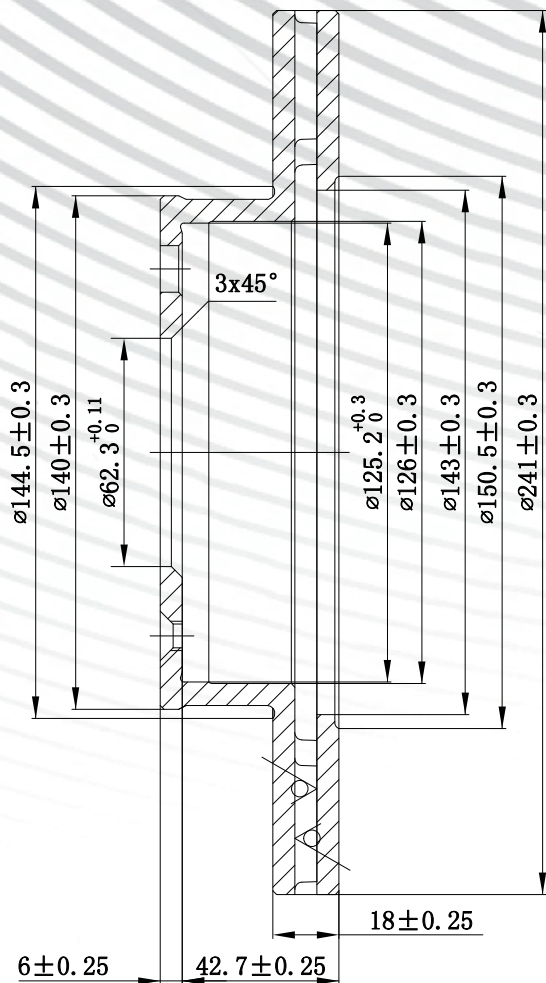

NPC DYNAMIK	FORMULACIÓN	ARMADORA	FREMAX	AÑO	DIÁMETRO	ALTO	ESPESOR	EJE
DNKE465STH	SMOOTH	KIA	BD7501	18/...	241 mm	48,7 mm	18 mm	DELANTERO
APLICACIÓN								
PICANTO ALL NEW MORNING 1.250cc								
PICANTO ALL NEW EKOTAXI + LX 1.0cc HATCH BACK PUBLICO RIN-13 Pastilla E465 (Largo 113.4mm)								

DNKD1593GMS

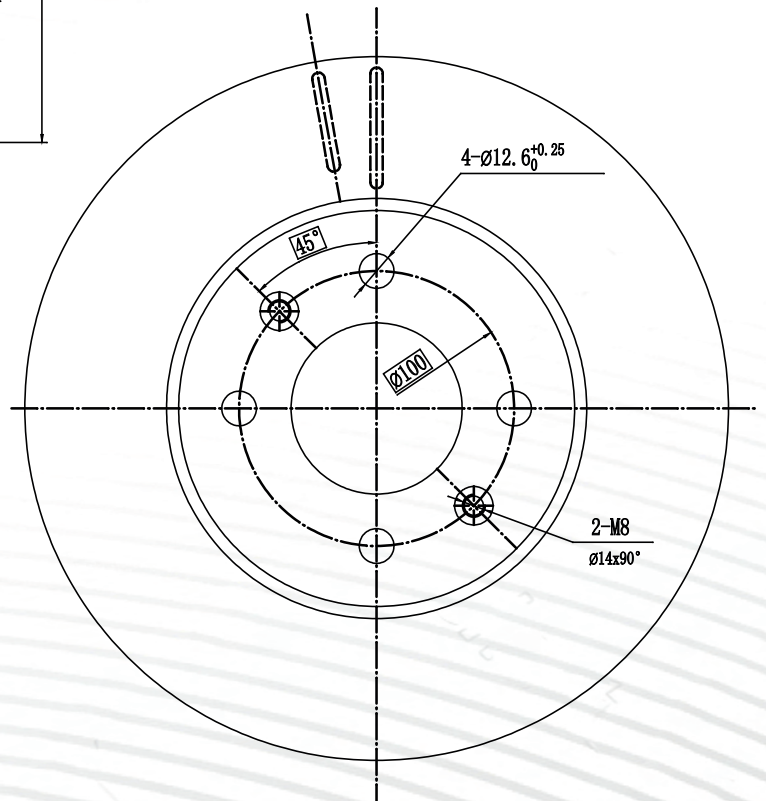
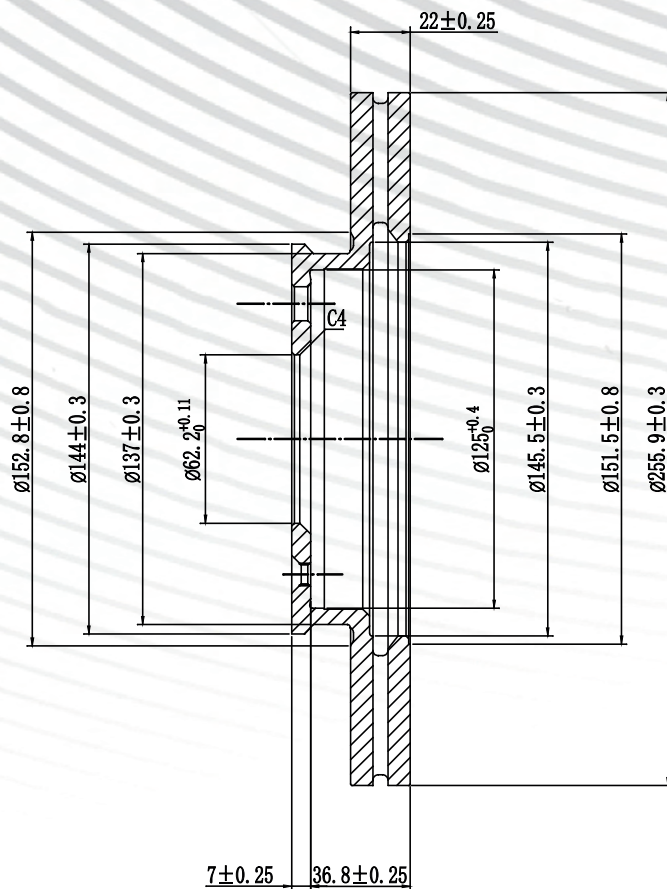

NPC DYNAMIK	FORMULACIÓN	ARMADORA	FREMAX	AÑO	DIÁMETRO	ALTO	ESPESOR	EJE
DNKD1593GMS	GEOMET	KIA	BD5206	12/ 14/...	255,9 mm	43,8 mm	22 mm	DELANTERO
APLICACIÓN								
RIO SPICE 1.4cc 1.6cc 16v i25								

DNKD320STH

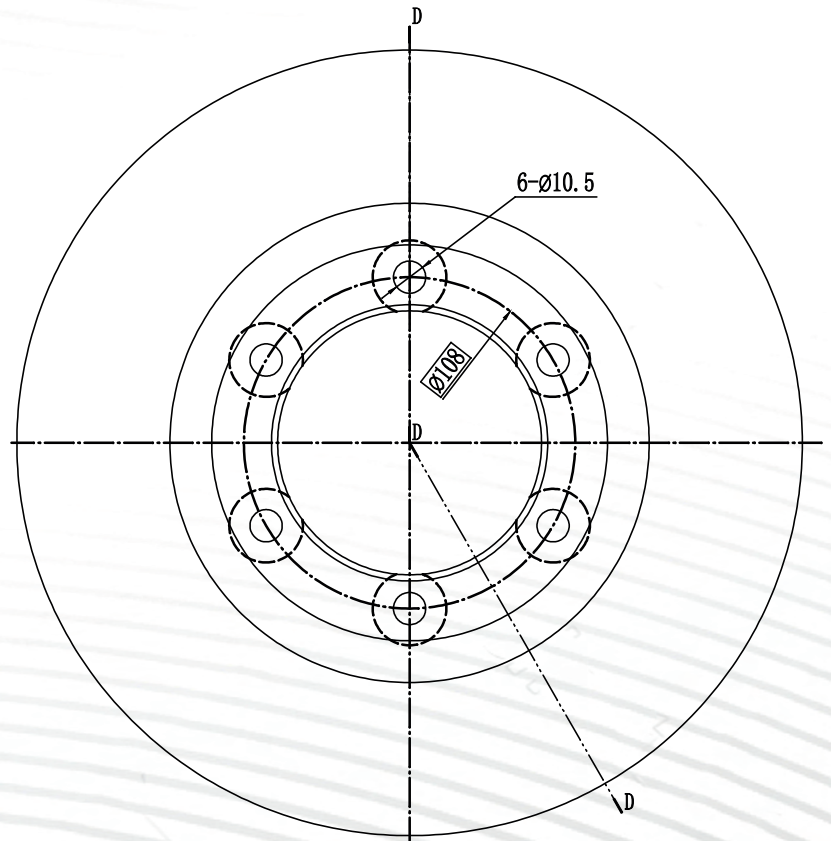
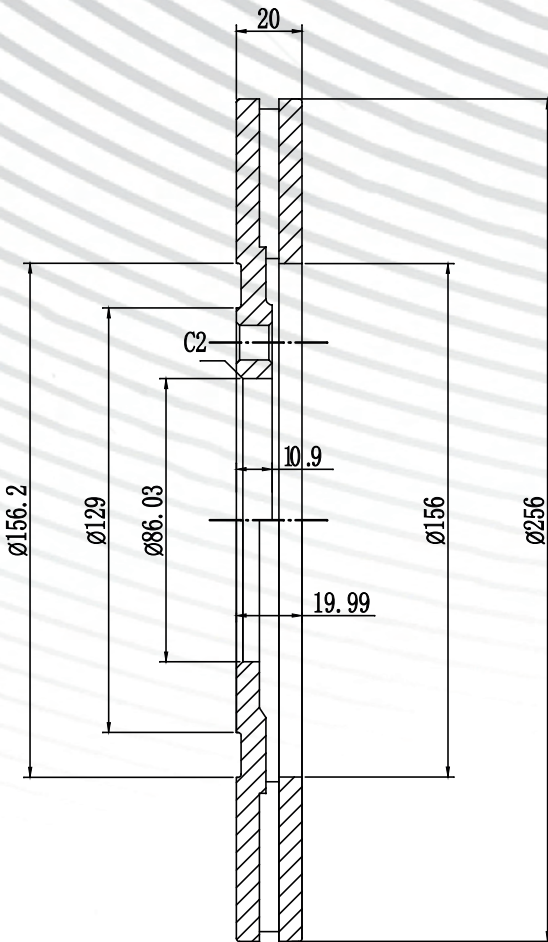

NPC DYNAMIK	FORMULACIÓN	ARMADORA	FREMAX	AÑO	DIÁMETRO	ALTO	ESPESOR	EJE
DNKD320STH	SMOOTH	KIA	BD0001	92/94	256 mm	19,99 mm	20 mm	DELANTERO
APLICACIÓN								
KIA BESTA 1993-1998 ; MAZDA B2000 1986-1987 ; MAZDA B2200 1987-1993 ; MAZDA B2600 1987-1993								

DNKD1544GMS

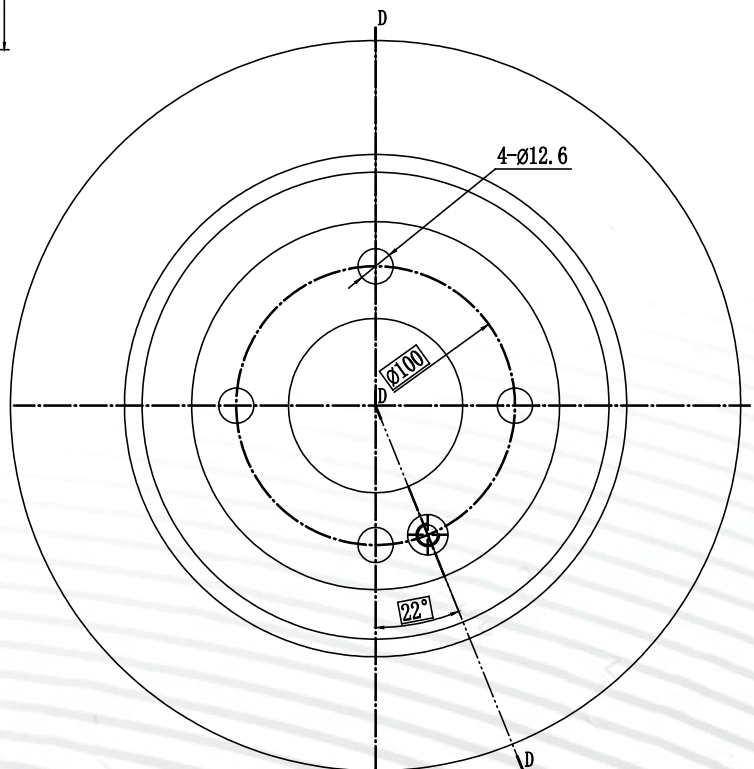
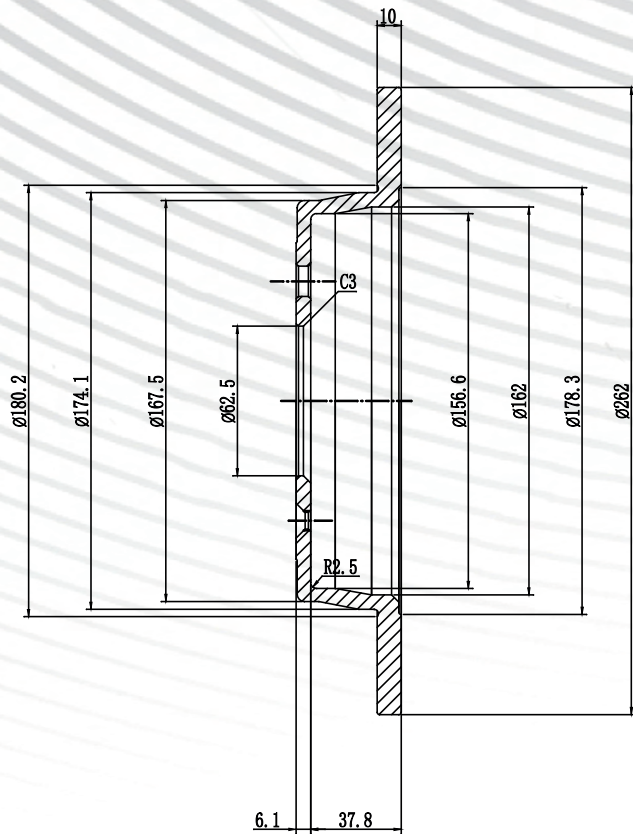

NPC DYNAMIK	FORMULACIÓN	ARMADORA	FREMAX	AÑO	DIÁMETRO	ALTO	ESPESOR	EJE
DNKD1544GMS	GEOMET	KIA	BD5201	14/...	262 mm	43,9 mm	10 mm	TRASERO
APLICACIÓN								
RIO SPICE 1.4cc 16v								

DNKD1397STH

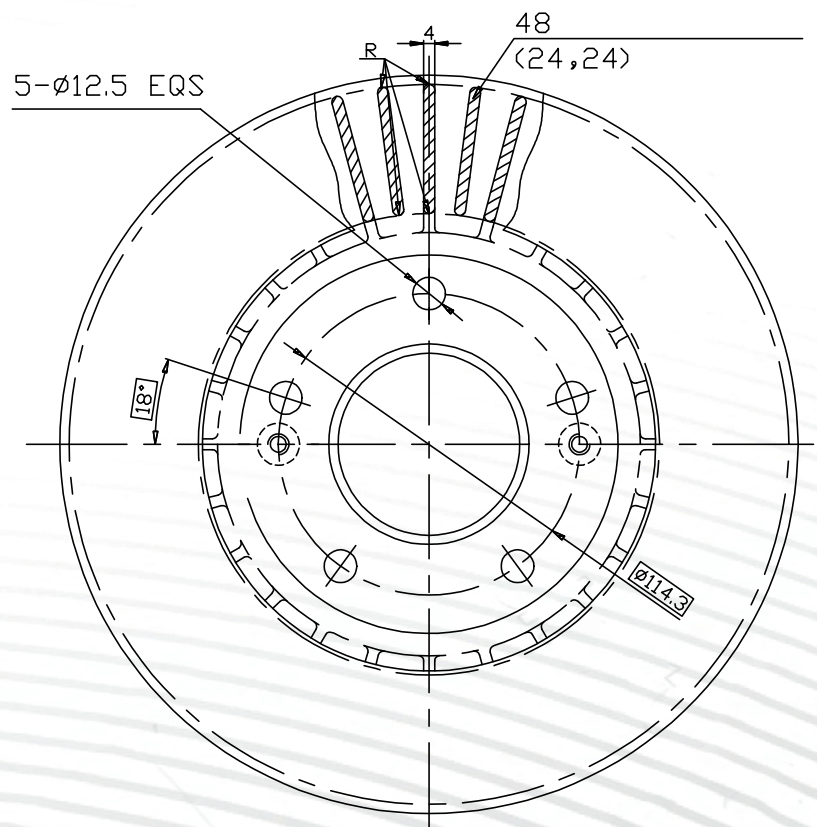
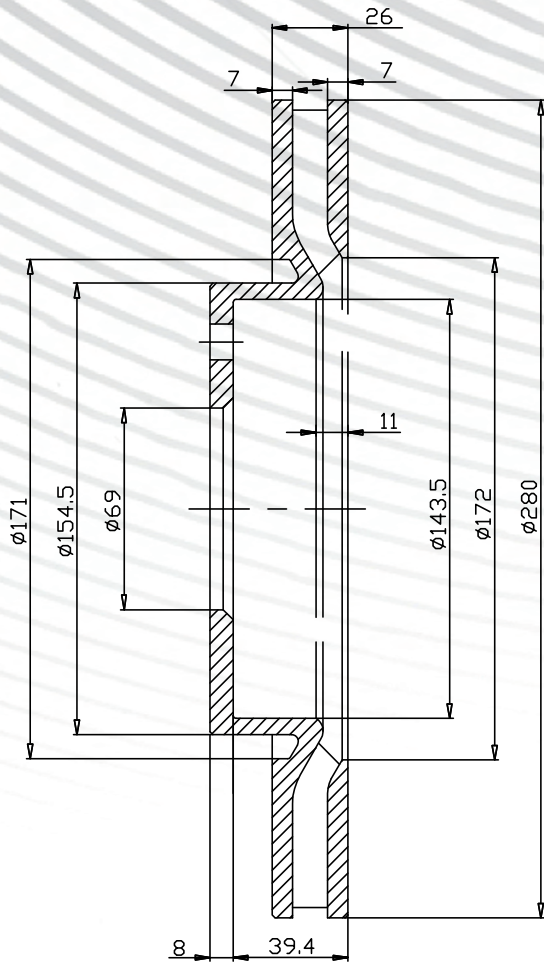

NPC DYNAMIK	FORMULACIÓN	ARMADORA	FREMAX	AÑO	DIÁMETRO	ALTO	ESPESOR	EJE
DNKD1397STH	SMOOTH	KIA	BD5158	10/... 13/...	280 mm	47,4 mm	26 mm	DELANTERO
APLICACIÓN								
CERATO III (TD) KOUP 2.0cc 16v CERATO FORTE SX 1.6cc HATCH BACK REF:OEM:517121M000								

DNKD1759GMS

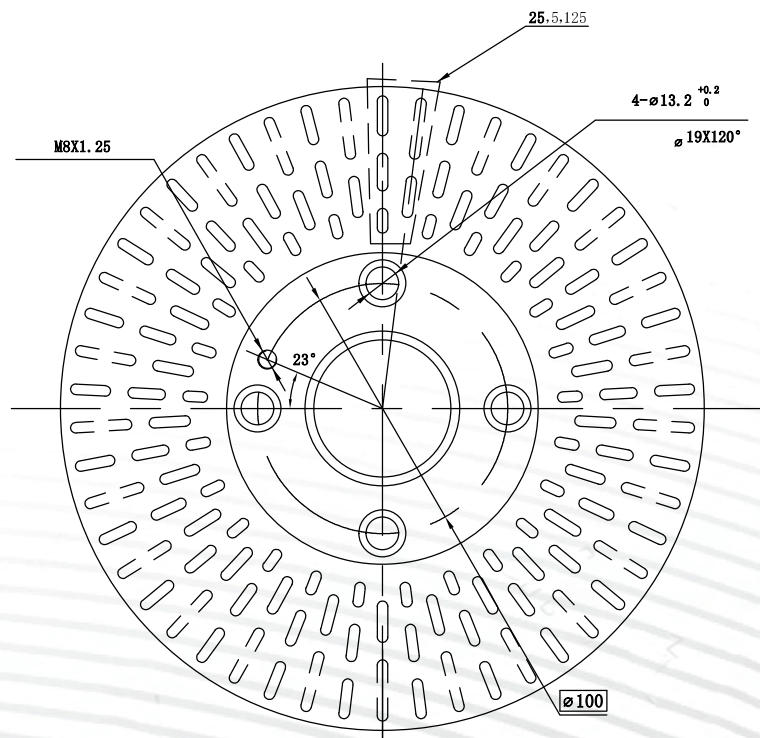
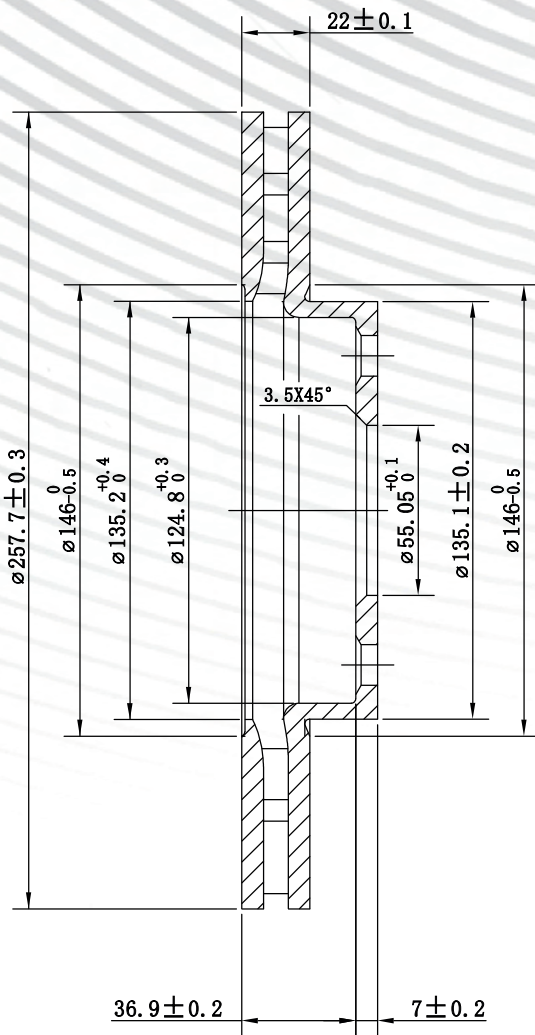

NPC DYNAMIK	FORMULACIÓN	ARMADORA	FREMAX	AÑO	DIÁMETRO	ALTO	ESPEJOR	EJE
DNKD1759GMS	GEOMET	MAZDA	BD0169	15/...	257,7 mm	43,9 mm	22 mm	DELANTERO
APLICACIÓN								
2 SKYACTIV 1.5cc								

DNKD1454GMS

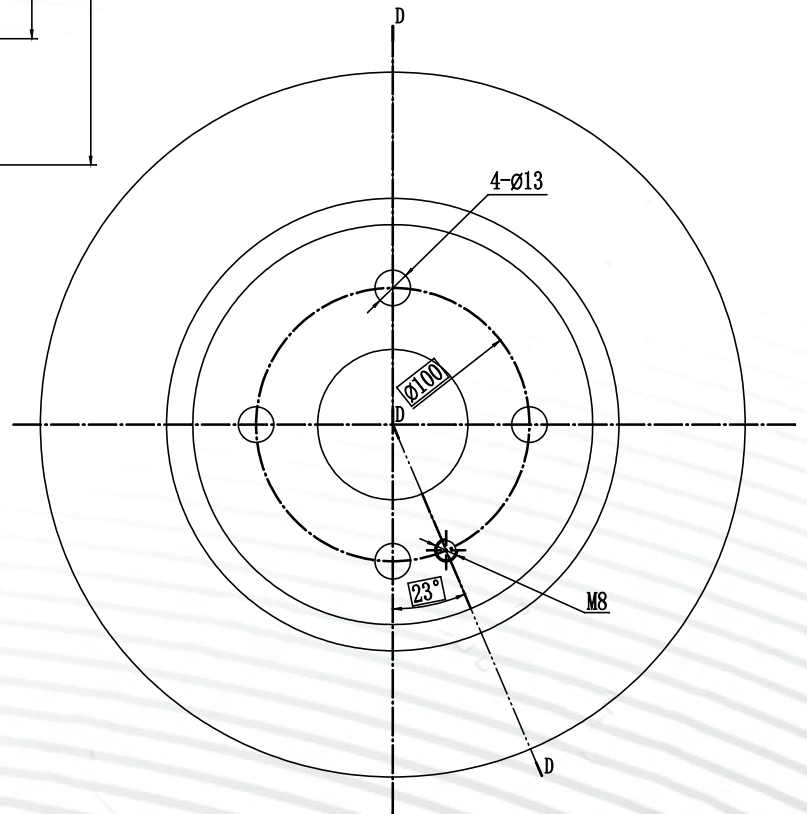
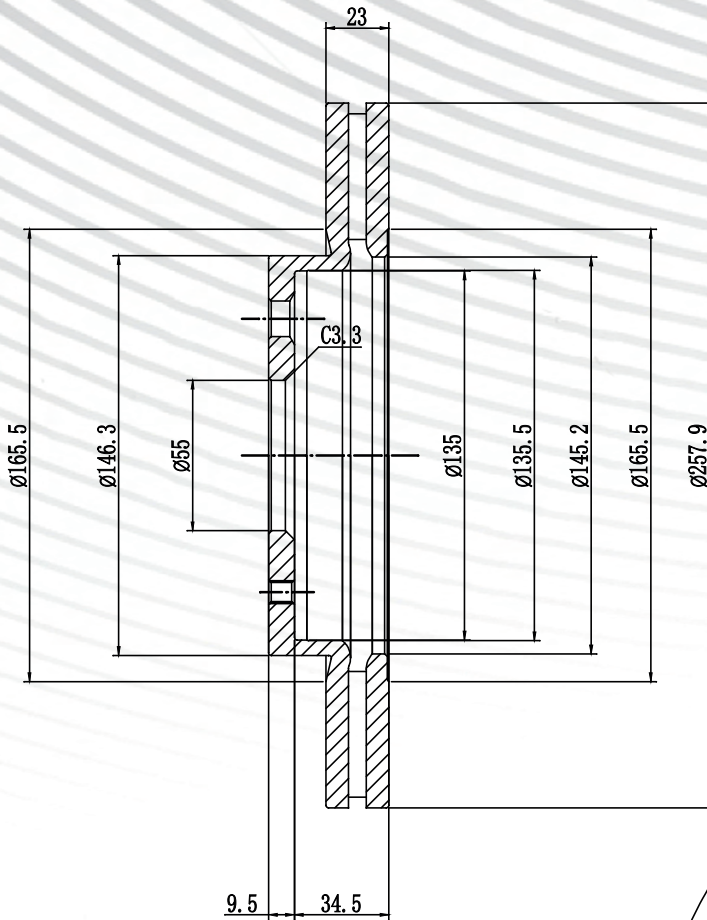

NPC DYNAMIK	FORMULACIÓN	ARMADORA	FREMAX	AÑO	DIÁMETRO	ALTO	ESPESOR	EJE
DNKD1454GMS	GEOMET	MAZDA	BD6036	08/15	257,9 mm	44 mm	23 mm	DELANTERO
APLICACIÓN								
MAZDA 2 1.5cc 1era Serie (DE) REF:OEM:DF71-33-251								

DNKD1679STH

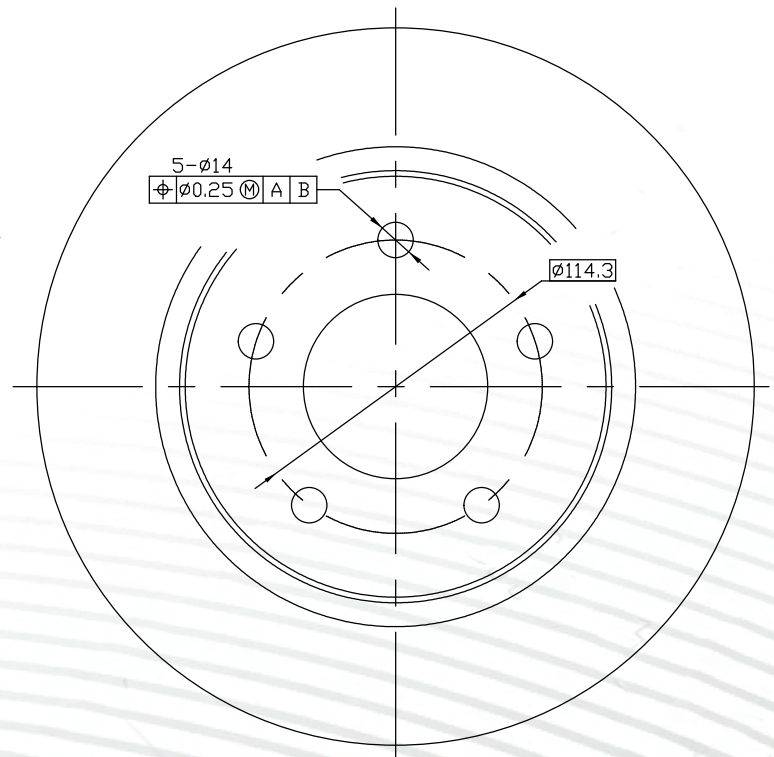
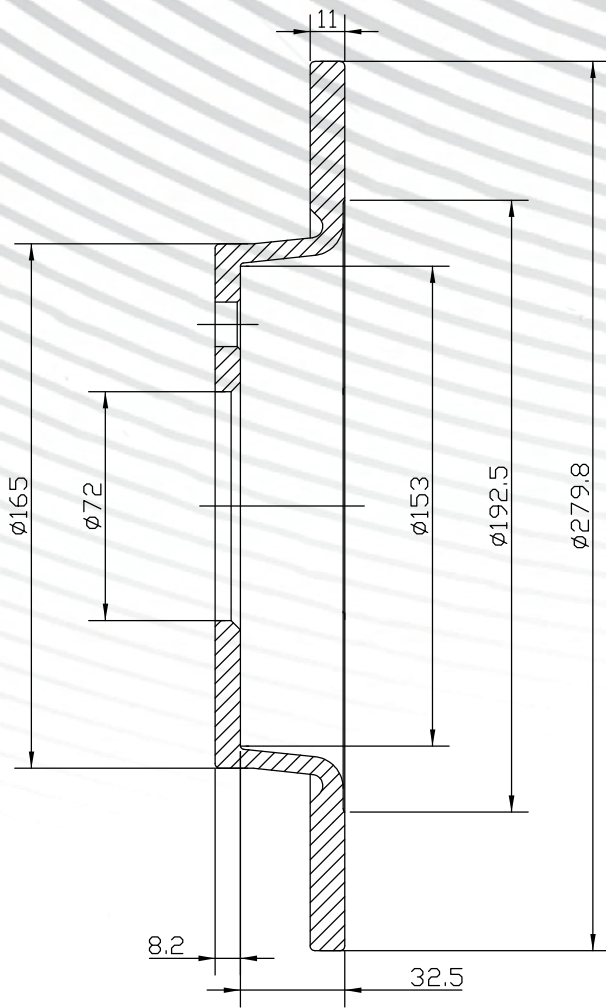

NPC DYNAMIK	FORMULACIÓN	ARMADORA	FREMAX	AÑO	DIÁMETRO	ALTO	ESPESOR	EJE
DNKD1679STH	SMOOTH	MAZDA	BD3276	15/...	279,8 mm	40,7 mm	11 mm	TRASERO
APLICACIÓN								
MAZDA 3 2.0cc SKYACTIV (Mexico) (BM;BN)								

DNKD1044GMS

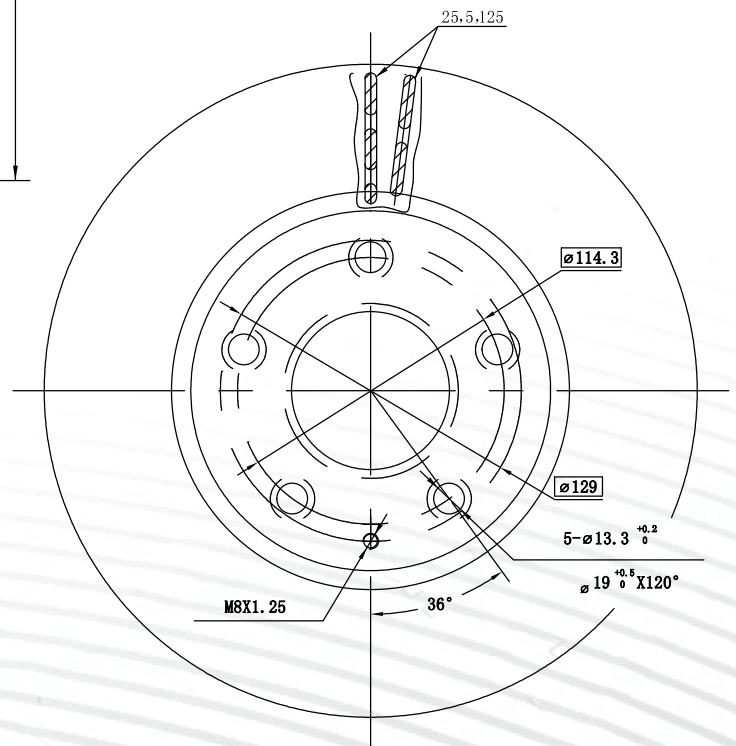
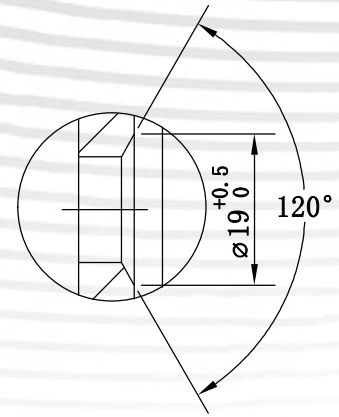
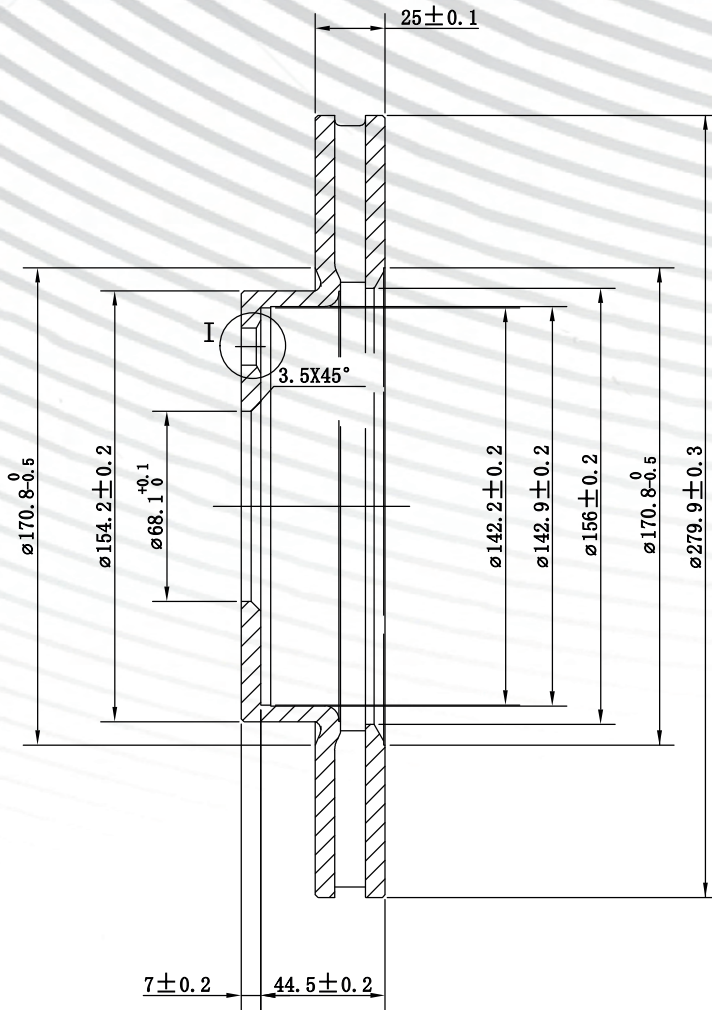

NPC DYNAMIK	FORMULACIÓN	ARMADORA	FREMAX	AÑO	DIÁMETRO	ALTO	ESPESOR	EJE
DNKD1044GMS	GEOMET	MAZDA	BD3563	09/13.	279,9 mm	51,5 mm	25 mm	DELANTERO
APLICACIÓN								
MAZDA 3 1.6 - 2.0cc ALLNEW								

DNKD1759STH

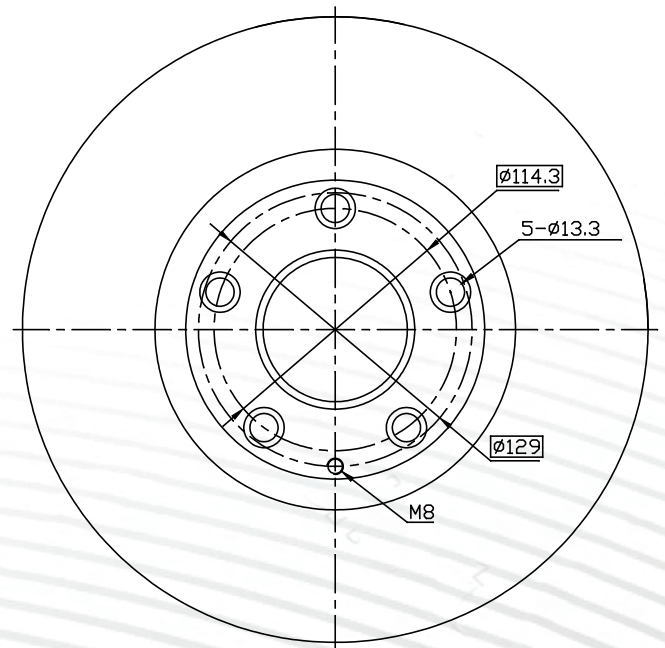
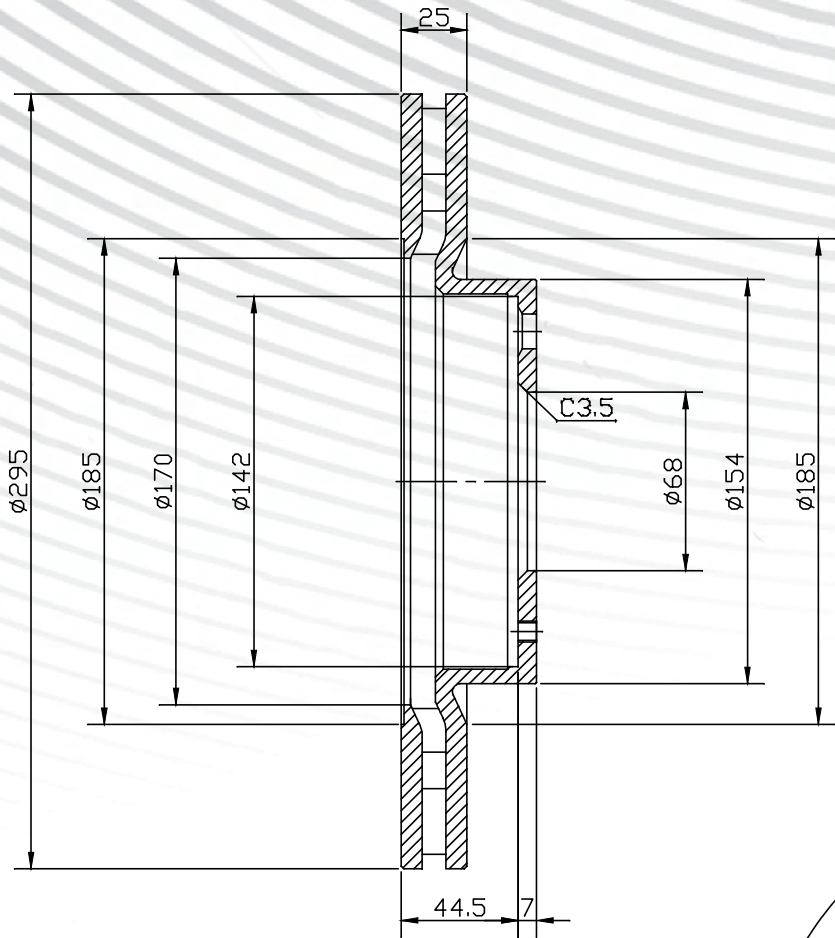

NPC DYNAMIK	FORMULACIÓN	ARMADORA	FREMAX	AÑO	DIÁMETRO	ALTO	ESPEJOR	EJE
DNKD1759STH	SMOOTH	MAZDA	BD3565	15/...	295 mm	51,5 mm	25 mm	DELANTERO
APLICACIÓN								
MAZDA 3 2.0cc SKYACTIV (Mexico) (BM;BN)								

DNKD399STH

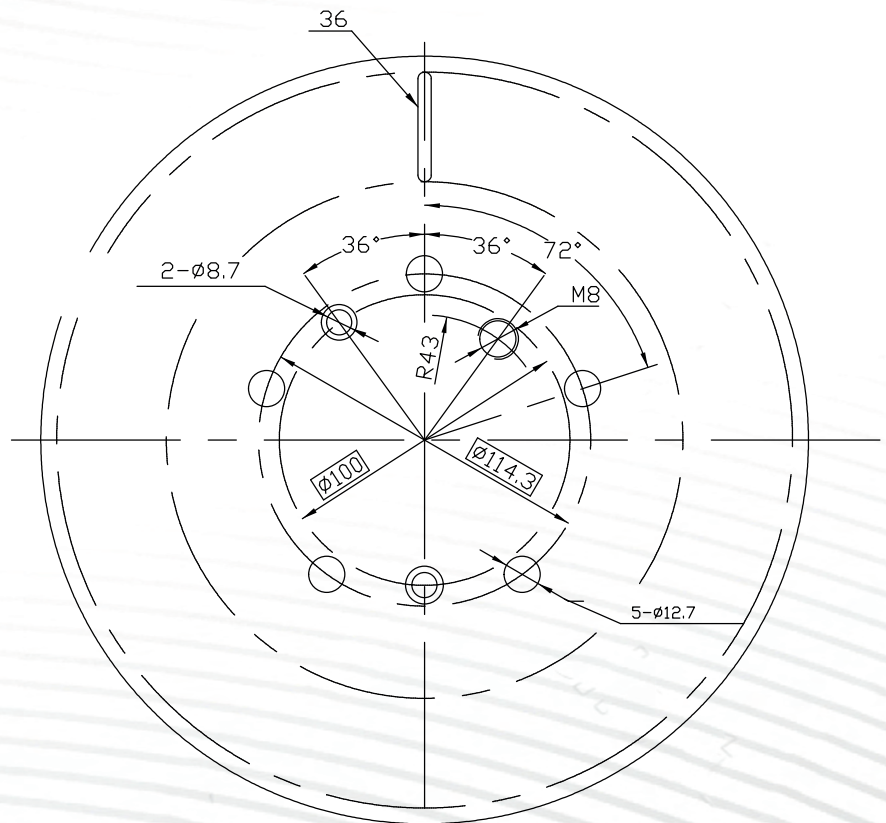
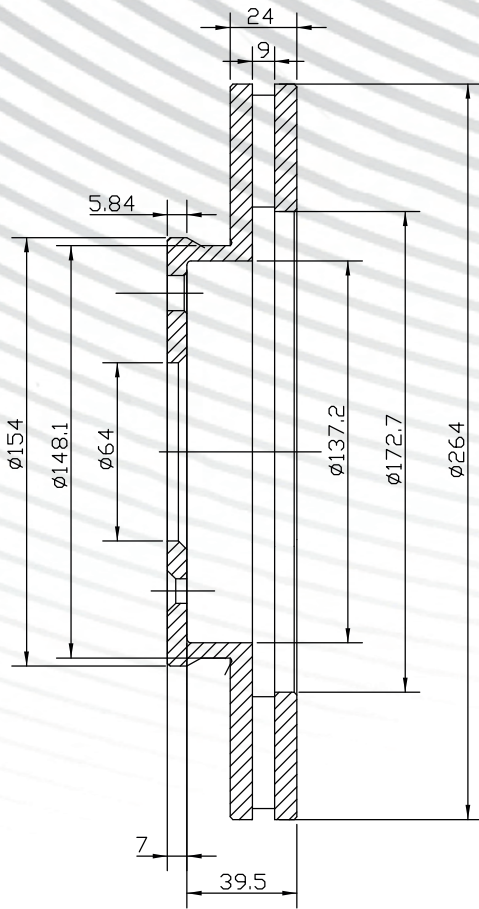

NPC DYNAMIK	FORMULACIÓN	ARMADORA	FREMAX	AÑO	DIÁMETRO	ALTO	ESPESOR	EJE
DNKD399STH	SMOOTH	MAZDA	BD3260	89/94	624 mm	46,5 mm	24 mm	DELANTERO
APLICACIÓN								
626 ASAHI 1.8cc, 2.0cc								

DNKD2038GMS

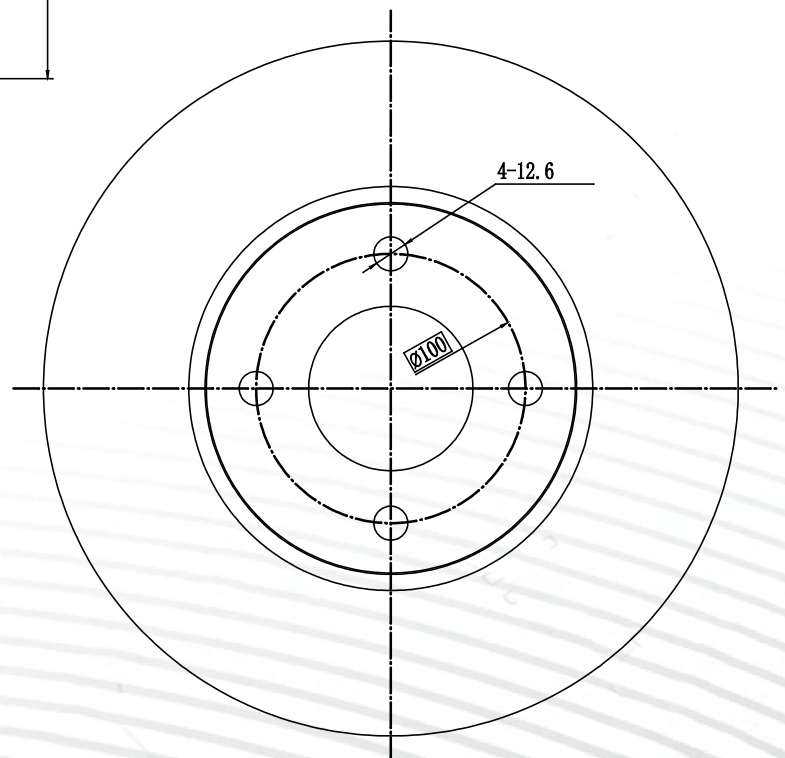
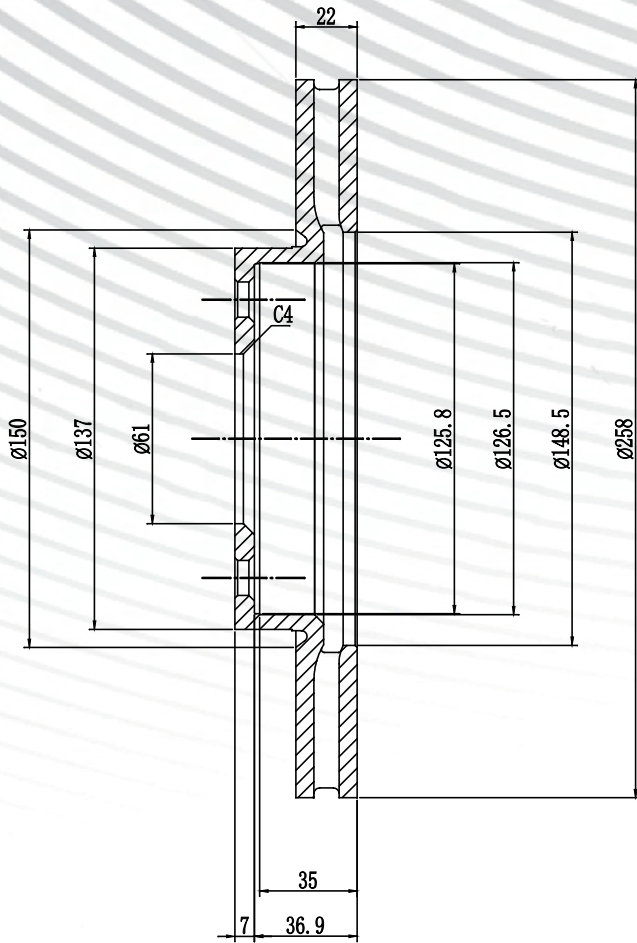

NPC DYNAMIK	FORMULACIÓN	ARMADORA	FREMAX	AÑO	DIÁMETRO	ALTO	ESPESOR	EJE
DNKD2038GMS	GEOMET	NISSAN	BD4758	17/...	258 mm	43,9 mm	22 mm	DELANTERO
APLICACIÓN								
KICKS 1.6cc								

DNKD1345STH

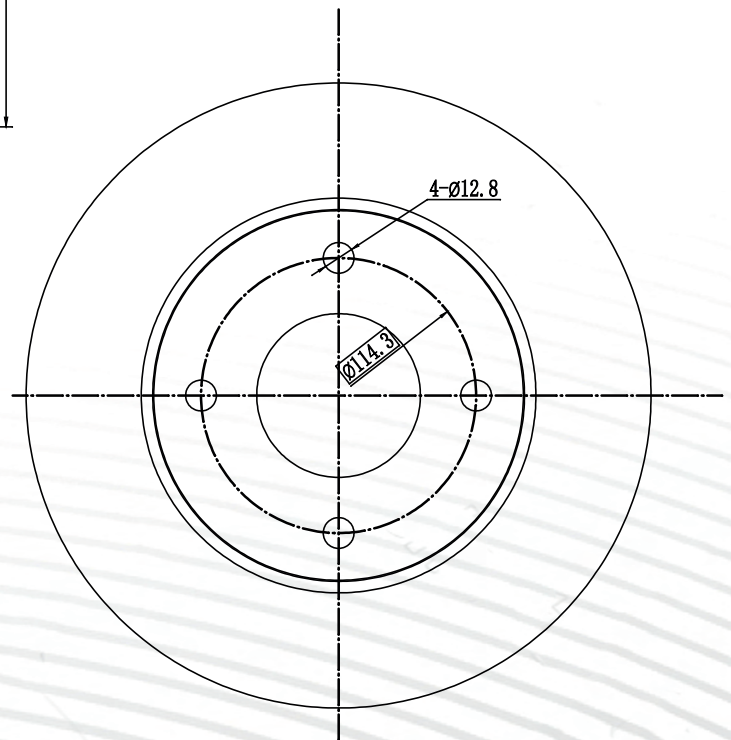
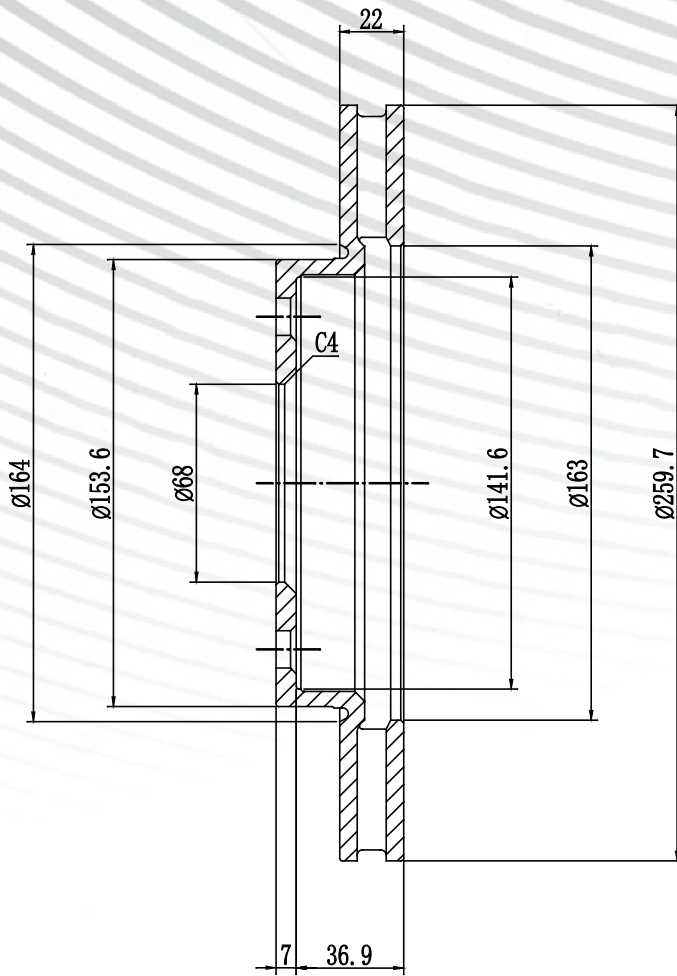

NPC DYNAMIK	FORMULACIÓN	ARMADORA	FREMAX	AÑO	DIÁMETRO	ALTO	ESPESOR	EJE
DNKD1345STH	SMOOTH	NISSAN	BD4738	08/...	259,7 mm	43,9 mm	22 mm	DELANTERO
APLICACIÓN								
TIIDA 1.8cc								

DNKD1592STH

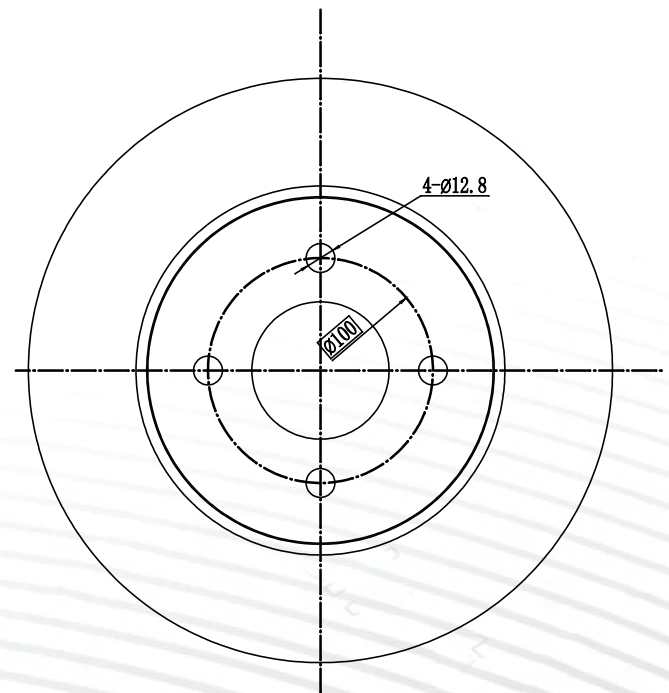
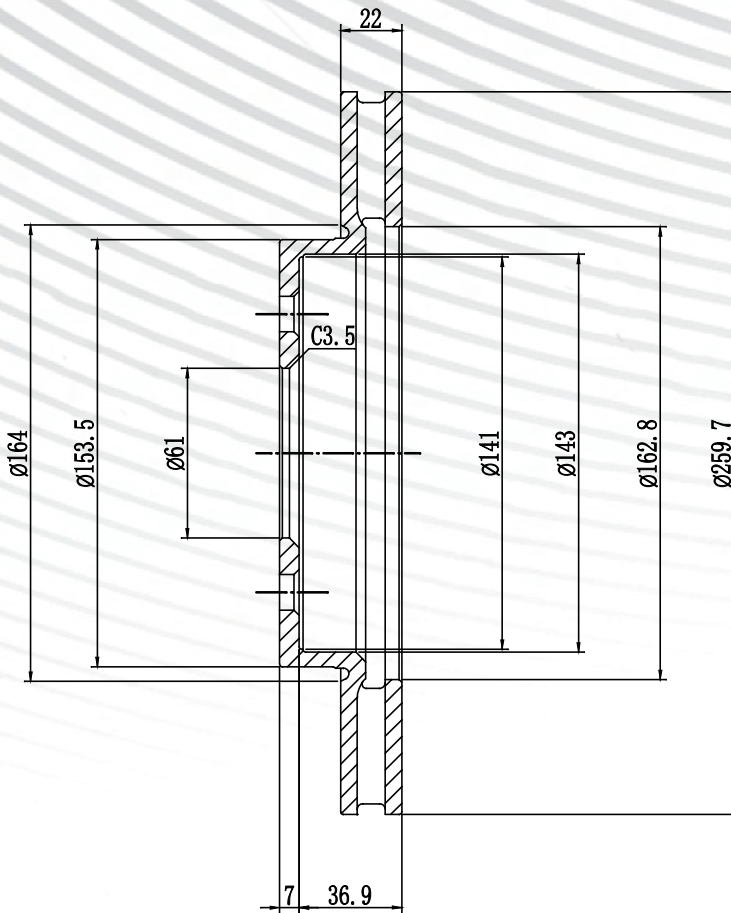

NPC DYNAMIK	FORMULACIÓN	ARMADORA	FREMAX	AÑO	DIÁMETRO	ALTO	ESPESOR	EJE
DNKD1592STH	SMOOTH	NISSAN	BD4740	11/17 12/18 15/..	259,7 mm	43,9 mm	22 mm	DELANTERO
APLICACIÓN								
MARCH 1.6cc 16v								

DNKD333STH

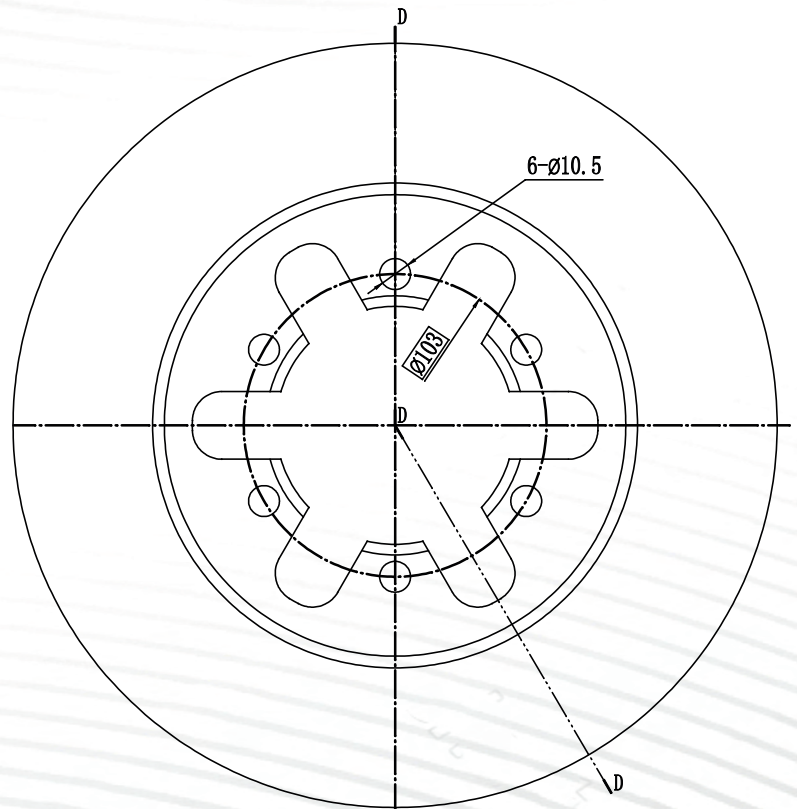
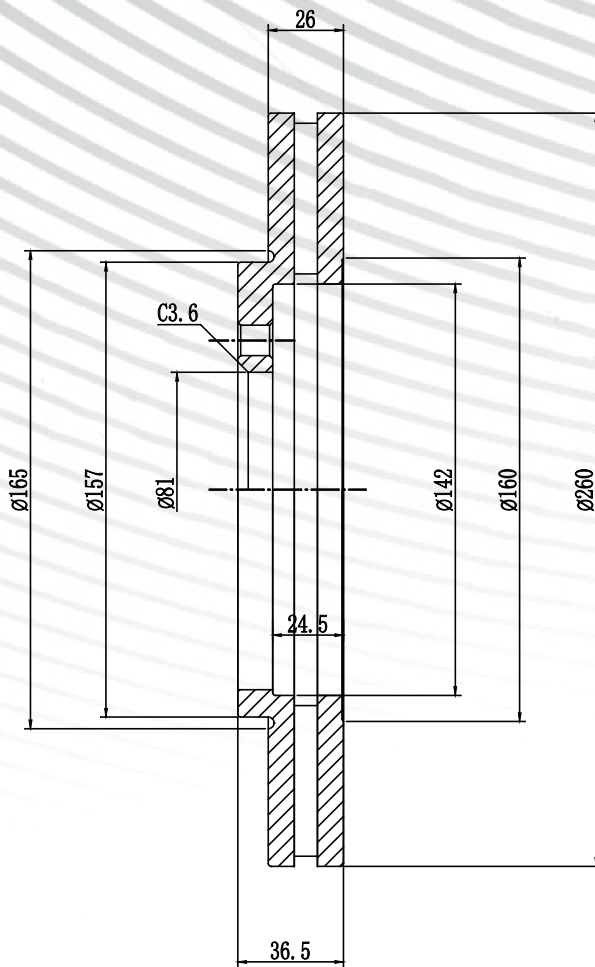

NPC DYNAMIK	FORMULACIÓN	ARMADORA	FREMAX	AÑO	DIÁMETRO	ALTO	ESPESOR	EJE
DNKD333STH	SMOOTH	NISSAN	BD6744	08/...	260 mm	36,5 mm	26 mm	DELANTERO
APLICACIÓN								
FRONTIER NP300 2.4cc, 2.5cc 4X2 D21 FRONTIER 2.4cc, 2.5cc 4X2 D22 FRONTIER 2.4cc, 2.5cc 4X2								

DNKD1191STH

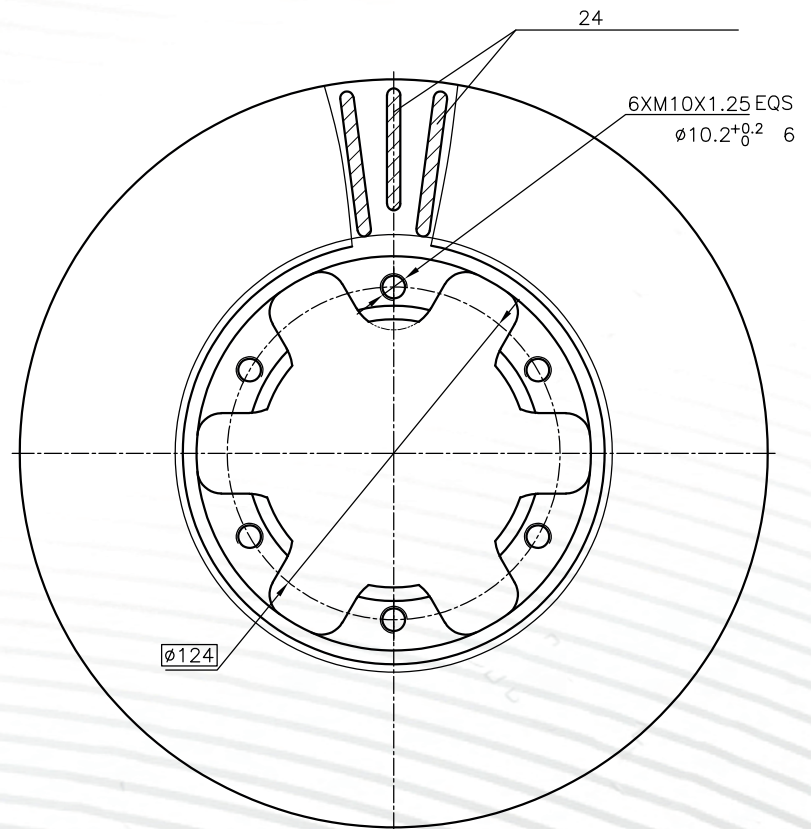
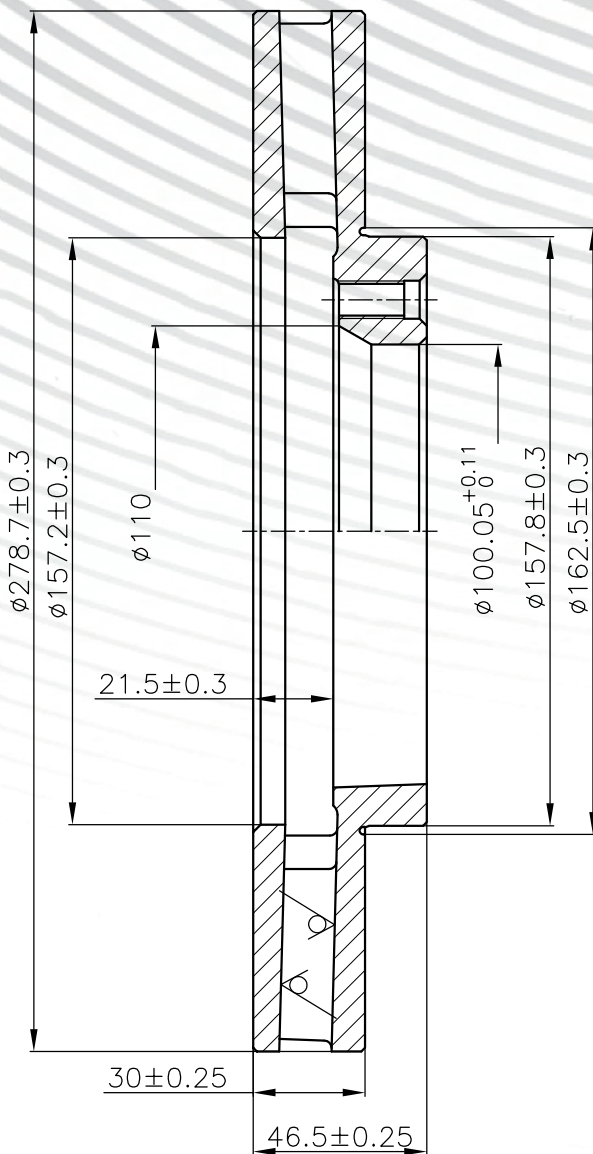

NPC DYNAMIK	FORMULACIÓN	ARMADORA	FREMAX	AÑO	DIÁMETRO	ALTO	ESPELOR	EJE
DNKD1191STH	SMOOTH	NISSAN	BD5205	98/...	278,7 mm	46,5 mm	30 mm	DELANTERO
APLICACIÓN								
URVAN 2.7cc, 3.0cc / NEW URVAN 2.7 cc ZD30 DIESEL								

DNKD1338STH

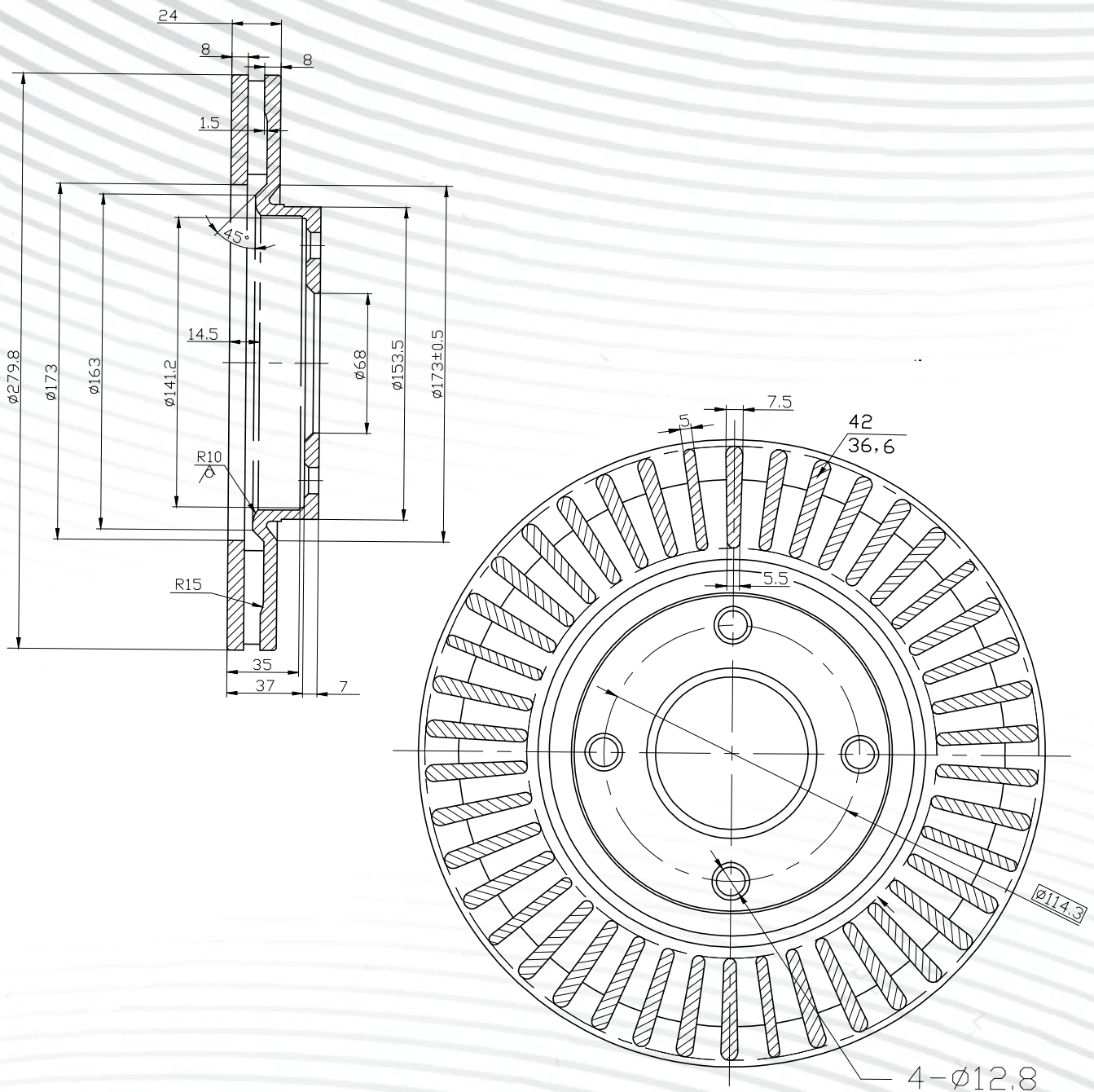

NPC DYNAMIK	FORMULACIÓN	ARMADORA	FREMAX	AÑO	DIÁMETRO	ALTO	ESPESOR	EJE
DNKD1338STH	SMOOTH	NISSAN	BD4206	07/...	279,8 mm	44 mm	24 mm	DELANTERO
APLICACIÓN								
SENTRA 2.0cc (B16) / VERSA								

DNKD1911STH

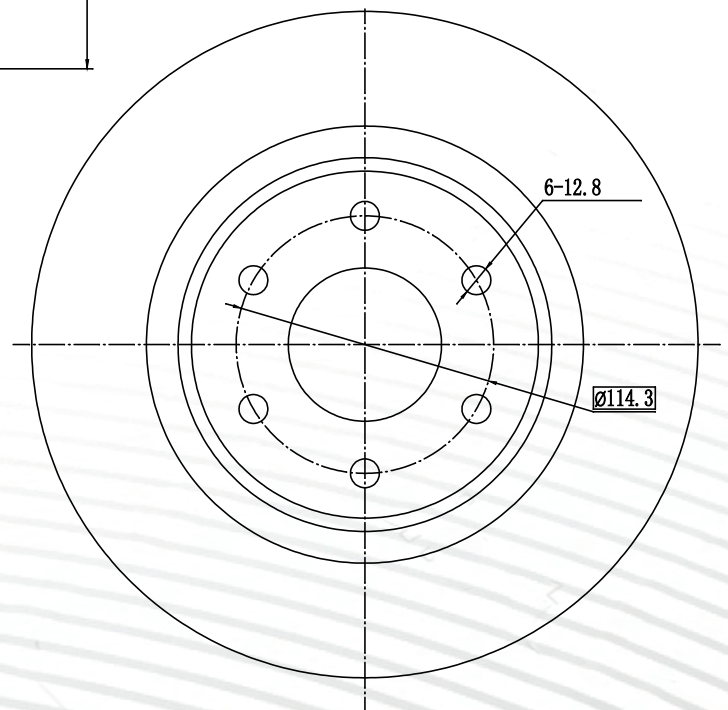
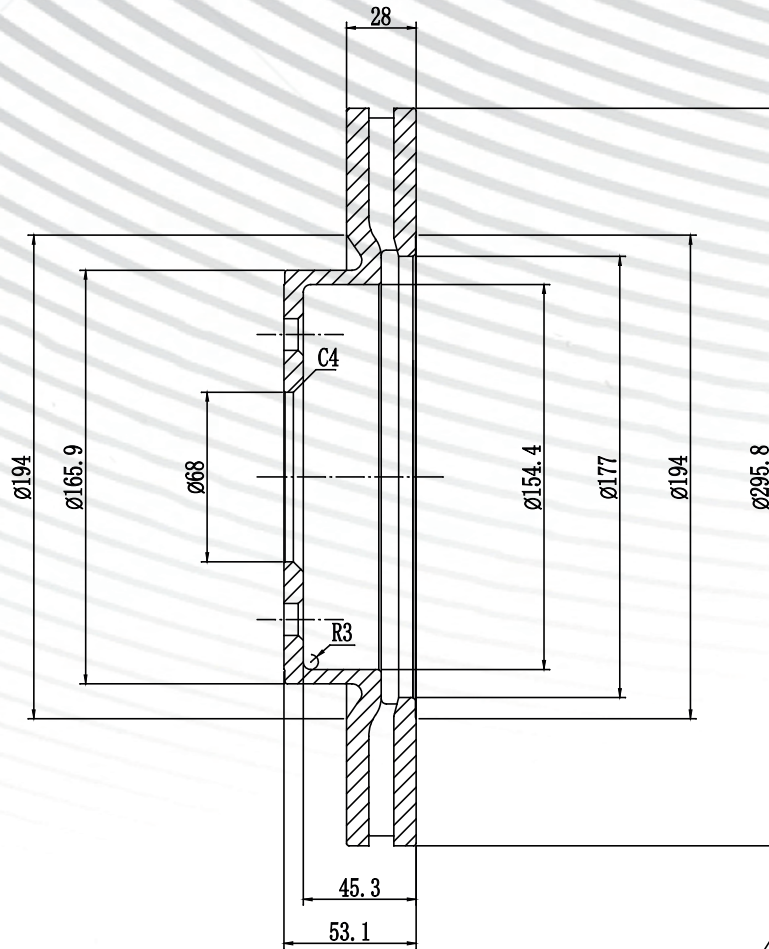

NPC DYNAMIK	FORMULACIÓN	ARMADORA	FREMAX	AÑO	DIÁMETRO	ALTO	ESPESOR	EJE
DNKD1911STH	SMOOTH	NISSAN	BD4198	08/...	295,8 mm	53,1 mm	28 mm	DELANTERO
APLICACIÓN								
FRONTIER NP300 DIESEL 2.5CC 4X4								

DNKD1737GMS

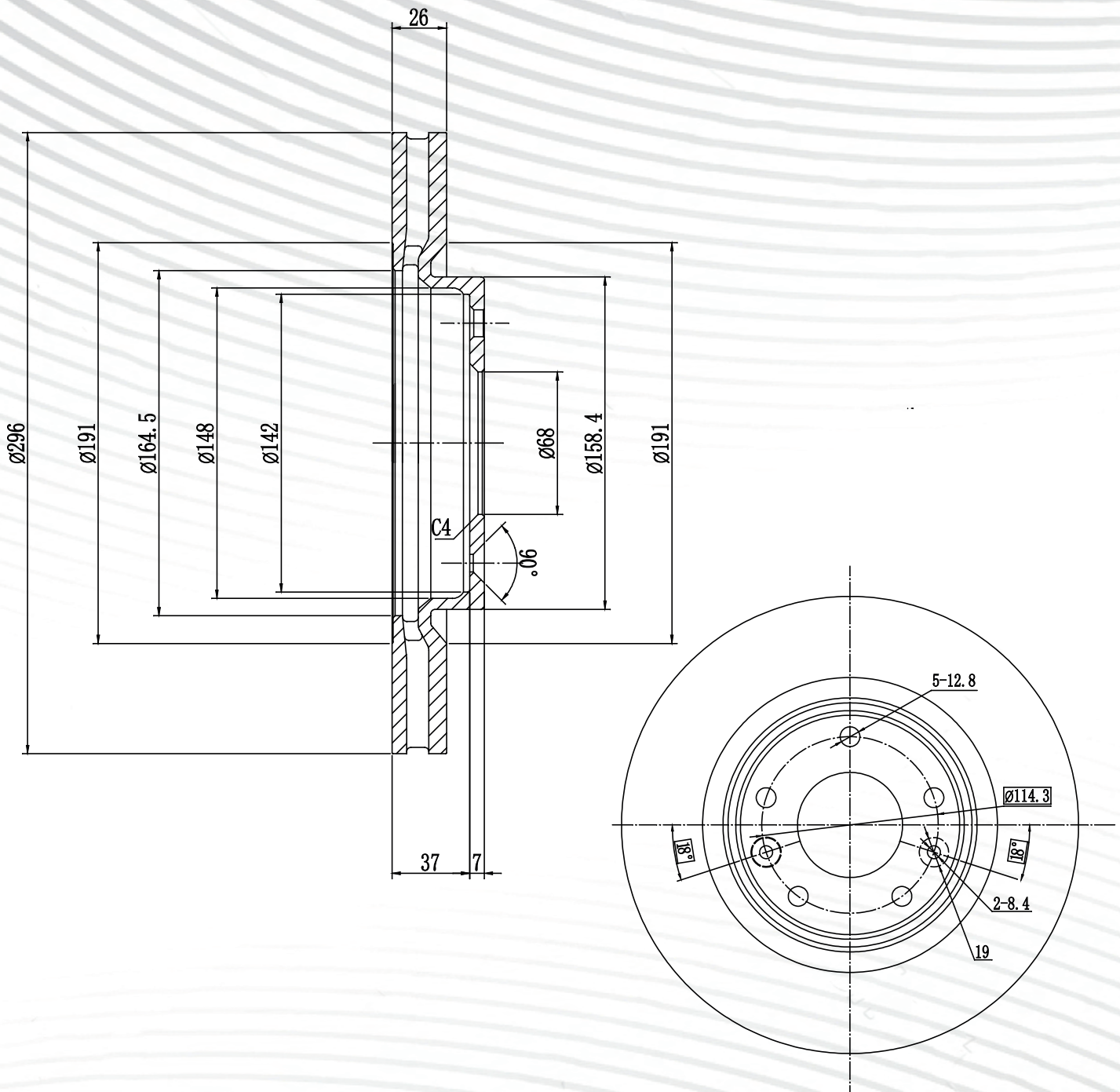

NPC DYNAMIK	FORMULACIÓN	ARMADORA	FREMAX	AÑO	DIÁMETRO	ALTO	ESPESOR	EJE
DNKD1737GMS	GEOMET	NISSAN	BD2089	17/...	296 mm	44 mm	26 mm	DELANTERO
APLICACIÓN								
QASHQAI 2.0cc Gasolina X-TRAIL T32 2.5cc Wagon Gasolina JUKE 1.6cc Hatch Back								

DNKD371STH

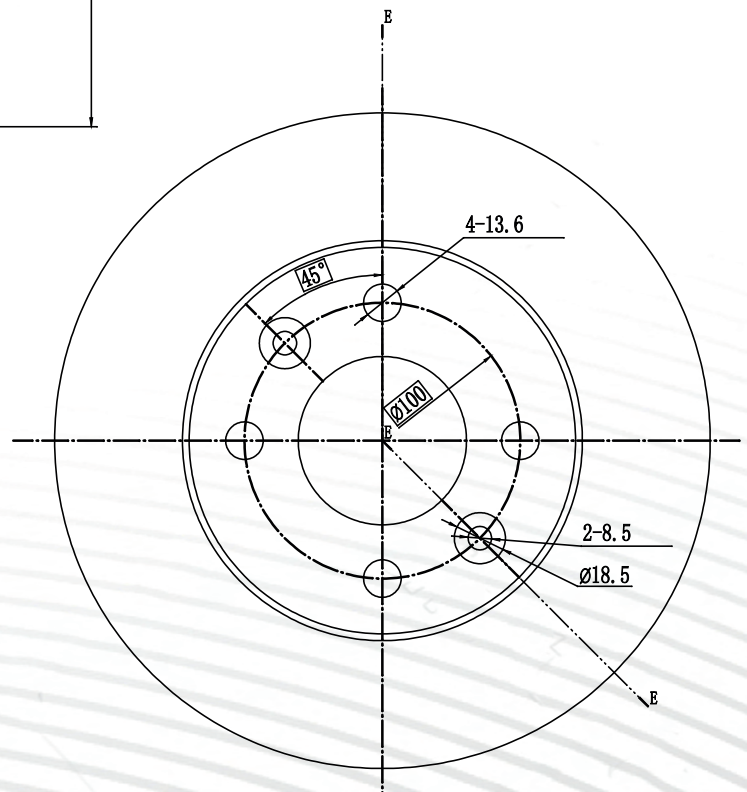
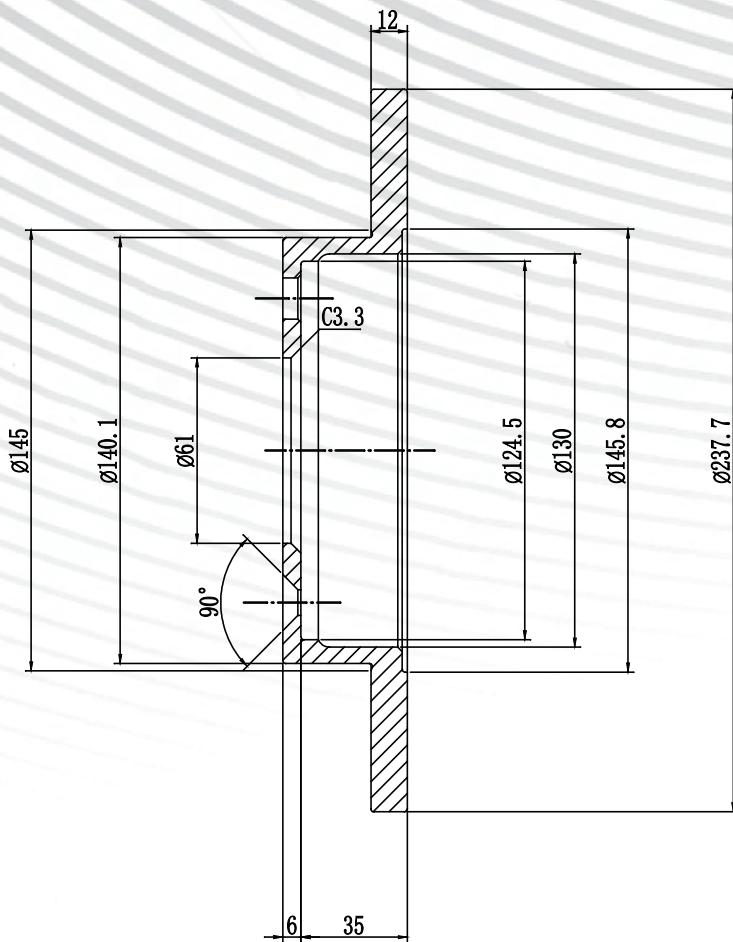

NPC DYNAMIK	FORMULACIÓN	ARMADORA	FREMAX	AÑO	DIÁMETRO	ALTO	ESPESOR	EJE
DNKD371STH	SMOOTH	RENAULT	BD4705	82/06	237,7 mm	41 mm	12 mm	DELANTERO
APLICACIÓN								
9 GLT 1.4cc / TWINGO FASE I ,II , III 1.2cc, 1.3 cc 8 valve								

DNKD1830STH

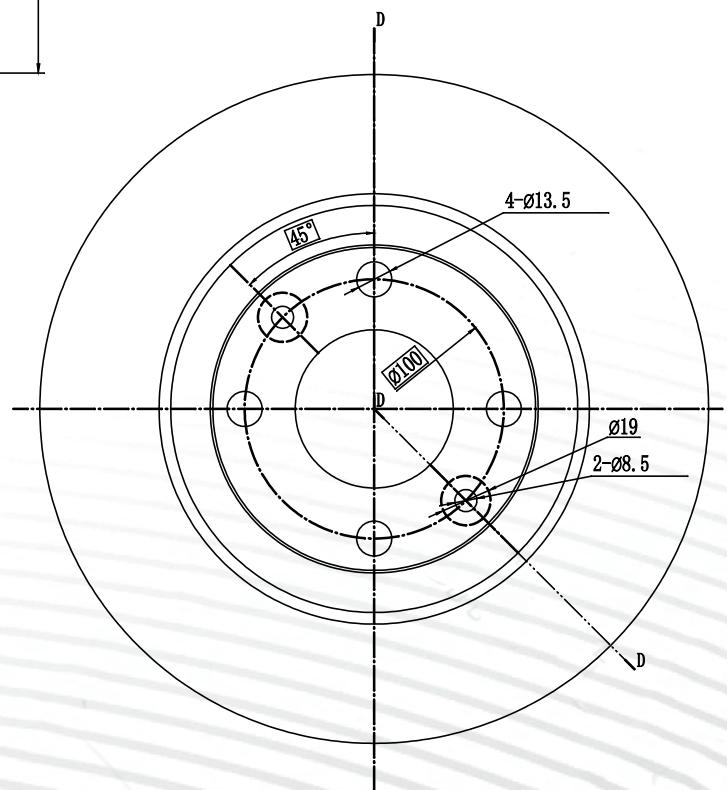
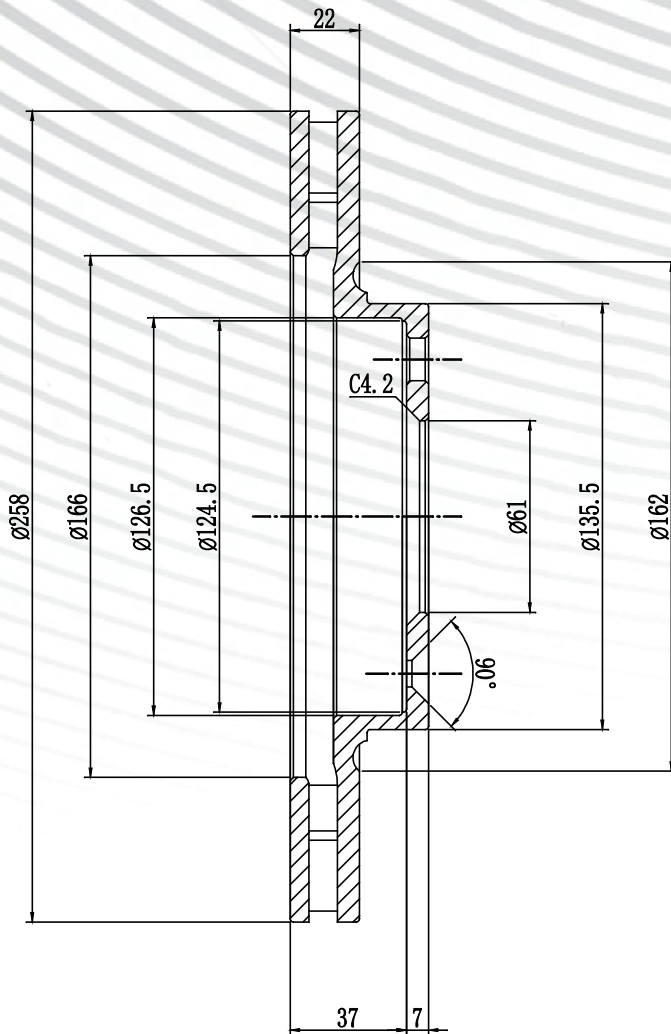

NPC DYNAMIK	FORMULACIÓN	ARMADORA	FREMAX	AÑO	DIÁMETRO	ALTO	ESPESOR	EJE
DNKD1830STH	SMOOTH	RENAULT	BD3108	15/...	258 mm	44 mm	22 mm	DELANTERO
APLICACIÓN								
LOGAN 1.6cc val / SANDERO 1.6 cc 16val / CLIO STYLE 1.2 cc/ CLIO SPORT STYLE 1.2 cc								

DNKD1146STH

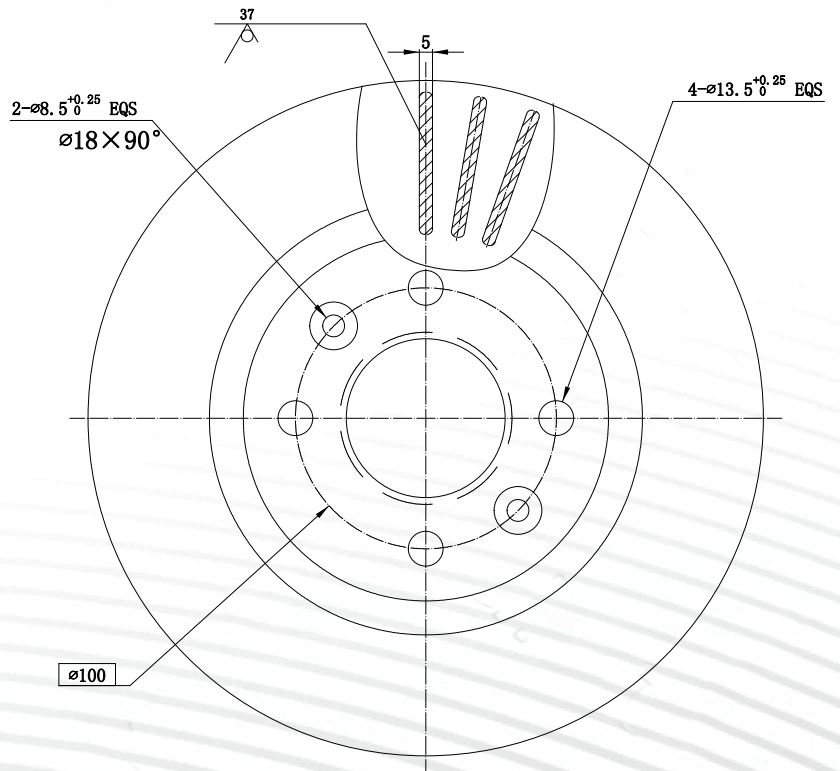
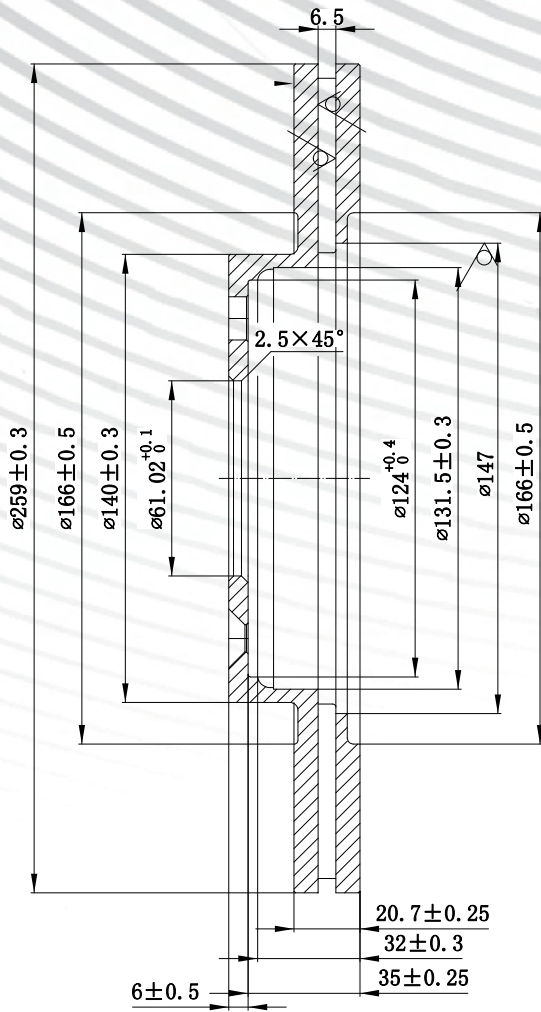

NPC DYNAMIK	FORMULACIÓN	ARMADORA	FREMAX	AÑO	DIÁMETRO	ALTO	ESPESOR	EJE
DNKD1146STH	SMOOTH	RENAULT	BD3550	99/...	259 mm	41 mm	20,7 mm	DELANTERO
APLICACIÓN								
CITIUS TAXI 1.4/LOGAN 1.6/SANDERO 1.6/MEGANE 1.4-1.6/CLIO 1.4/SYMBOL 1.4/KANGOO/METROPOLI TAXI								

DNKD1627STH

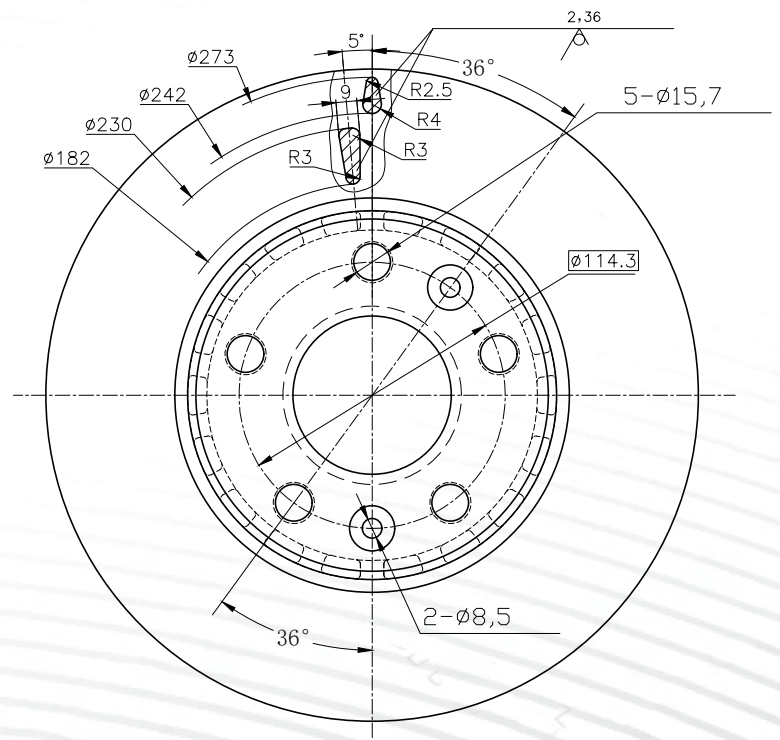
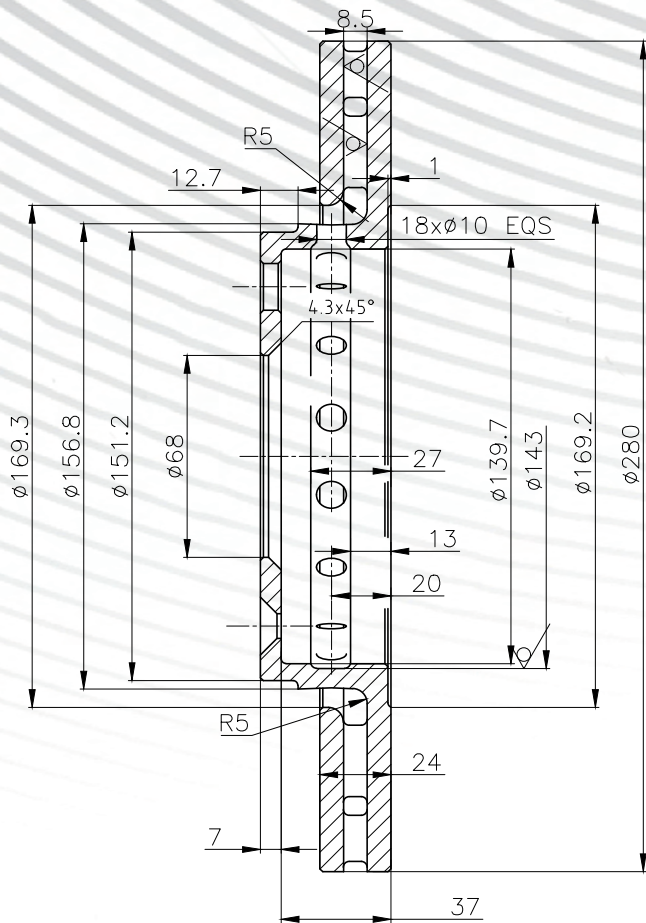

NPC DYNAMIK	FORMULACIÓN	ARMADORA	FREMAX	AÑO	DIÁMETRO	ALTO	ESPESOR	EJE
DNKD1627STH	SMOOTH	RENAULT	BD4022	12/... 11/... 17/... 16/...	280 mm	44 mm	24 mm	DELANTERO
APLICACIÓN								
DUSTER 2.0cc 16v 4X2, 4X4 MEGANE III 2.0cc 16v FLUENCE 1.6cc 16v FLUENCE 2.0cc 16v								

DNKD1736STH

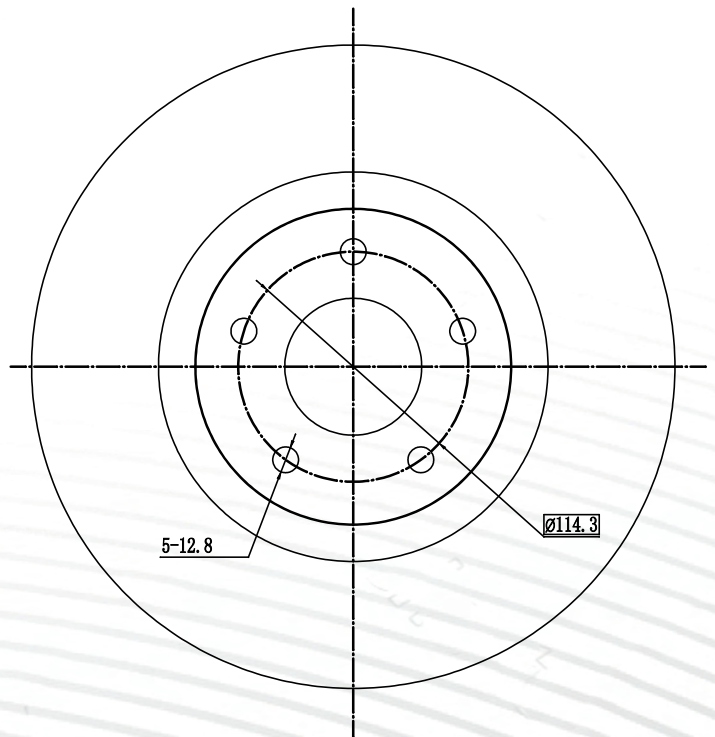
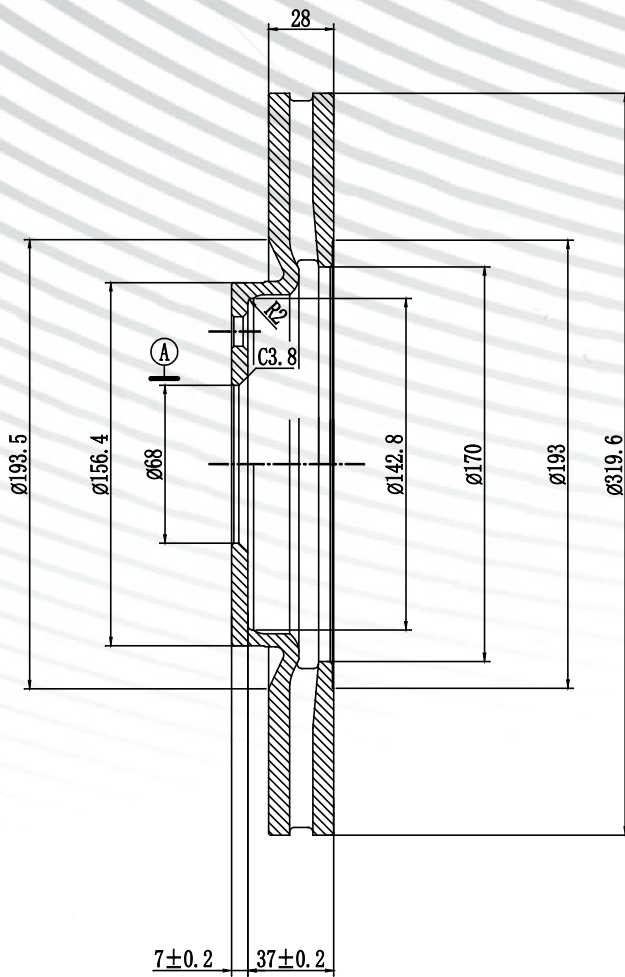

NPC DYNAMIK	FORMULACIÓN	ARMADORA	FREMAX	AÑO	DIÁMETRO	ALTO	ESPEXOR	EJE
DNKD1736STH	SMOOTH	RENAULT	BD2059	11/... 11/... 09/...	319,6 mm	44 mm	28 mm	DELANTERO
APLICACIÓN								
KOLEOS 2.0cc 16v TD 4WD - KOLEOS 2.5cc 16v 2WD - KOLEOS 2.5cc 16v 4WD REF: ORIGINAL # 40206-ET01A								

DNKD303GMS

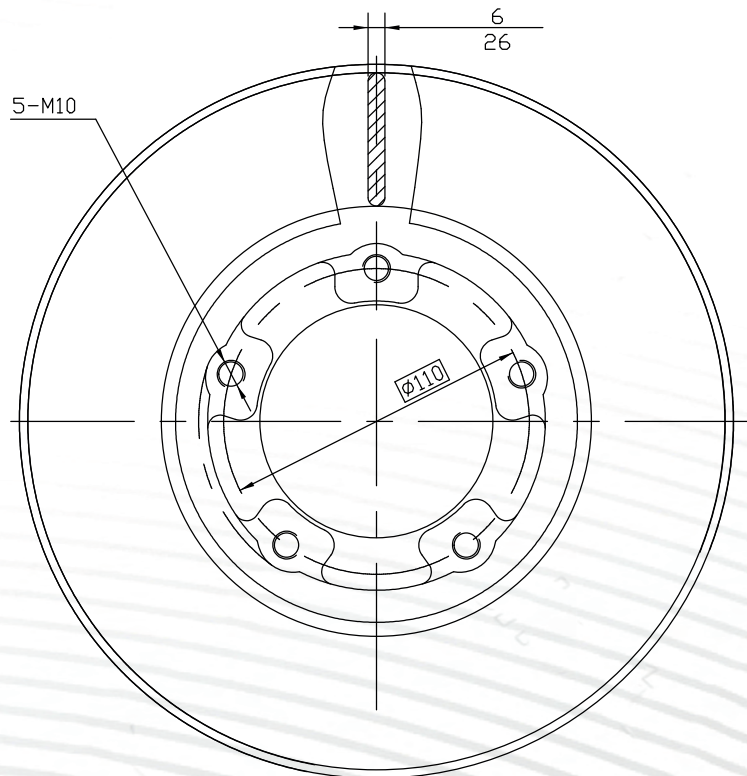
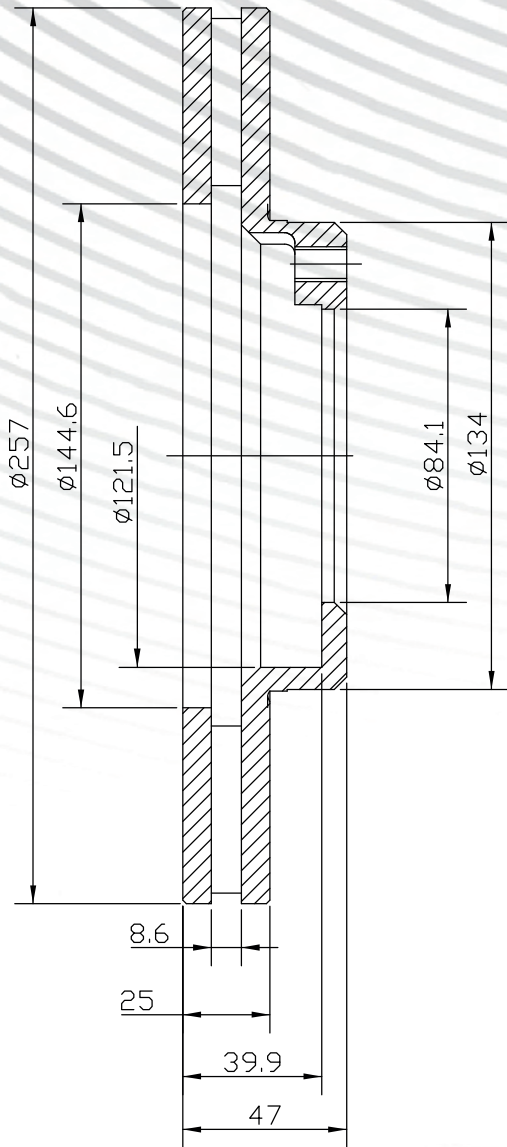

NPC DYNAMIK	FORMULACIÓN	ARMADORA	FREMAX	AÑO	DIÁMETRO	ALTO	ESPESOR	EJE
DNKD303GMS	GEOMET	TOYOTA	BD5180	93/04	257 mm	47 mm	25 mm	DELANTERO
APLICACIÓN								
HILUX 4X2								

DNKD436GMS

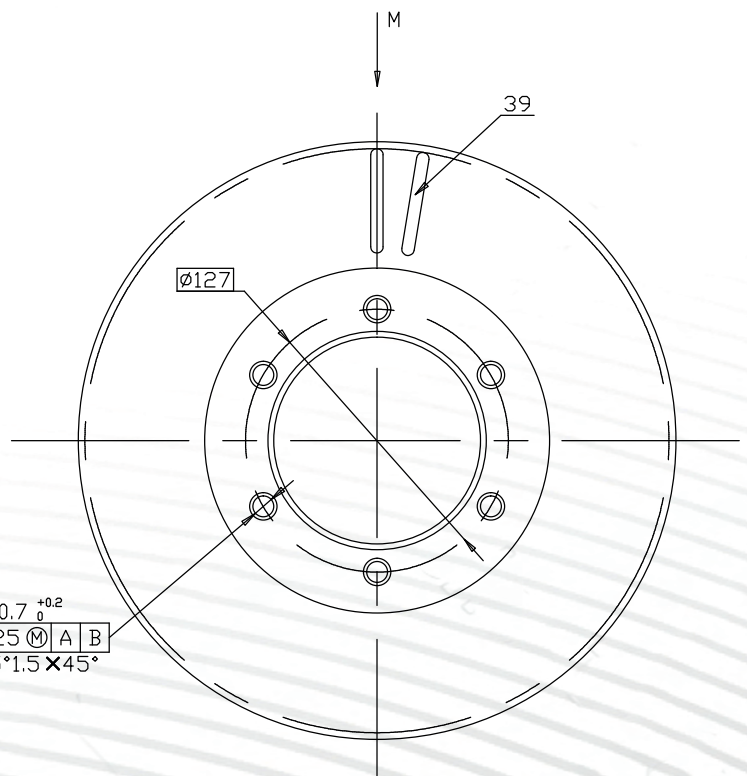
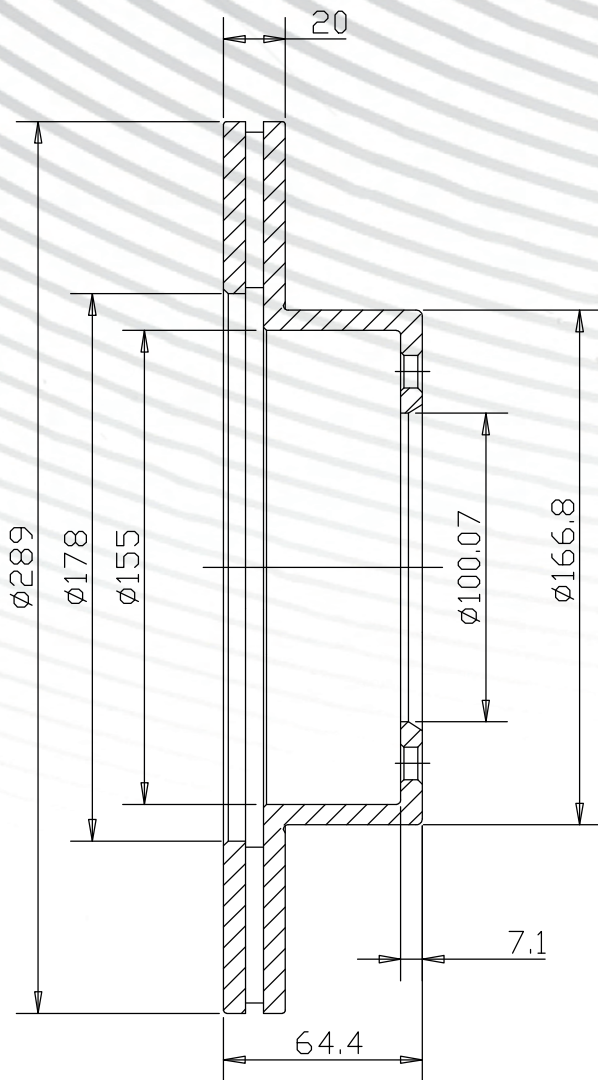

NPC DYNAMIK	FORMULACIÓN	ARMADORA	FREMAX	AÑO	DIÁMETRO	ALTO	ESPELOR	EJE
DNKD436GMS	GEOMET	TOYOTA	BD5190	89/07	289 mm	64,4 mm	20 mm	DELANTERO
APLICACIÓN								
HILUX 2.4cc, 4X4 / 4 RUNNER II 3.0cc 4X4								

DNKD1567STH

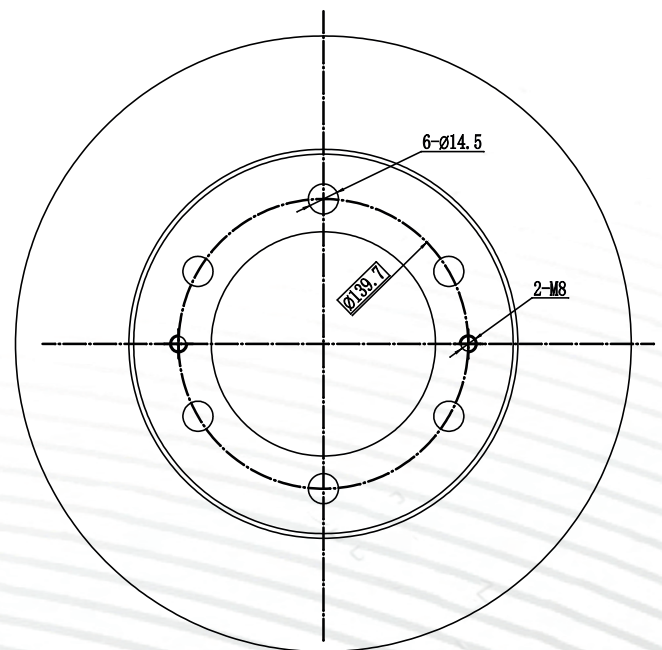
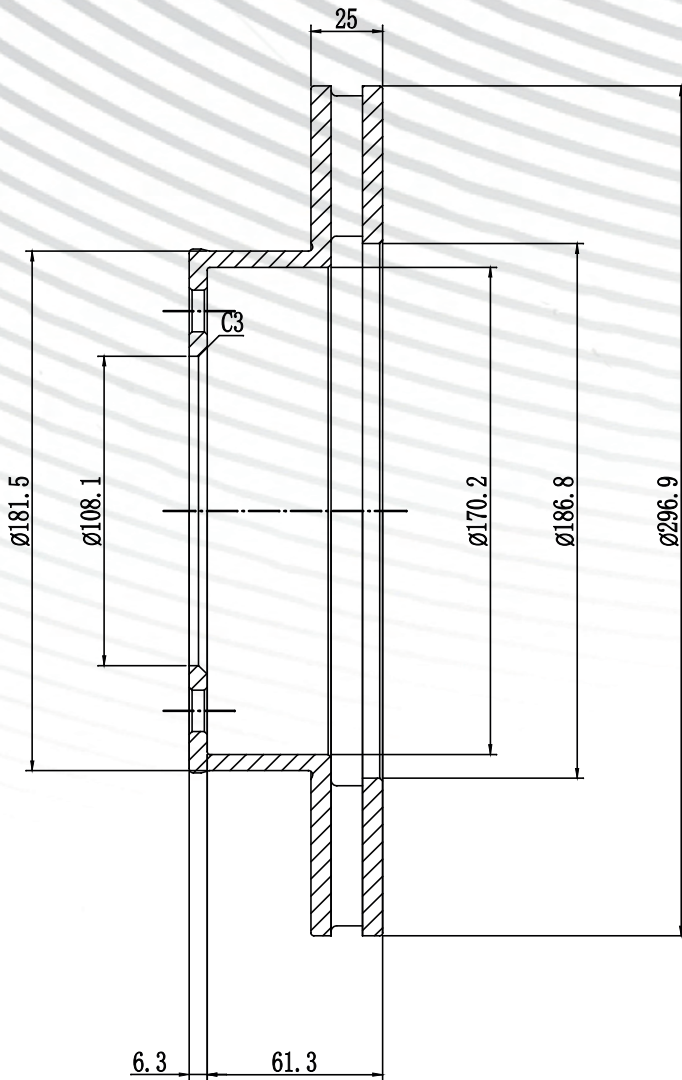

NPC DYNAMIK	FORMULACIÓN	ARMADORA	FREMAX	AÑO	DIÁMETRO	ALTO	ESPESOR	EJE
DNKD1567STH	SMOOTH	TOYOTA	BD4211	06/...	296,9 mm	67,6 mm	25 mm	DELANTERO
APLICACIÓN								
NEW HILUX VIIGO 4X2 4X4 IMV 2.5cc, 2.7cc, 3.0cc								

DNKD436STH

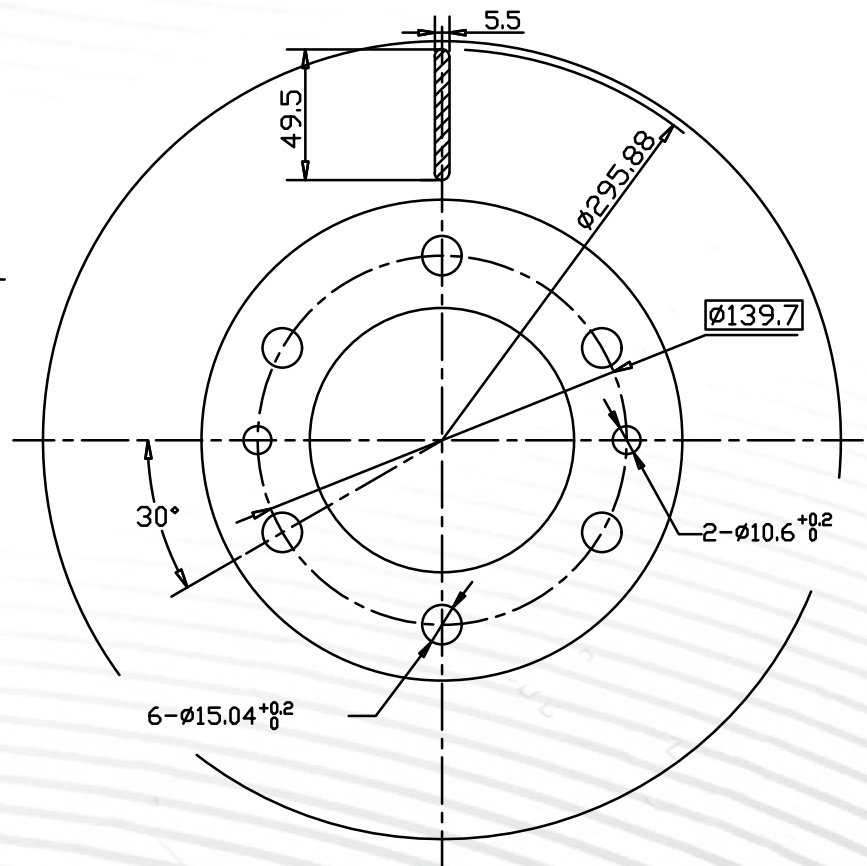
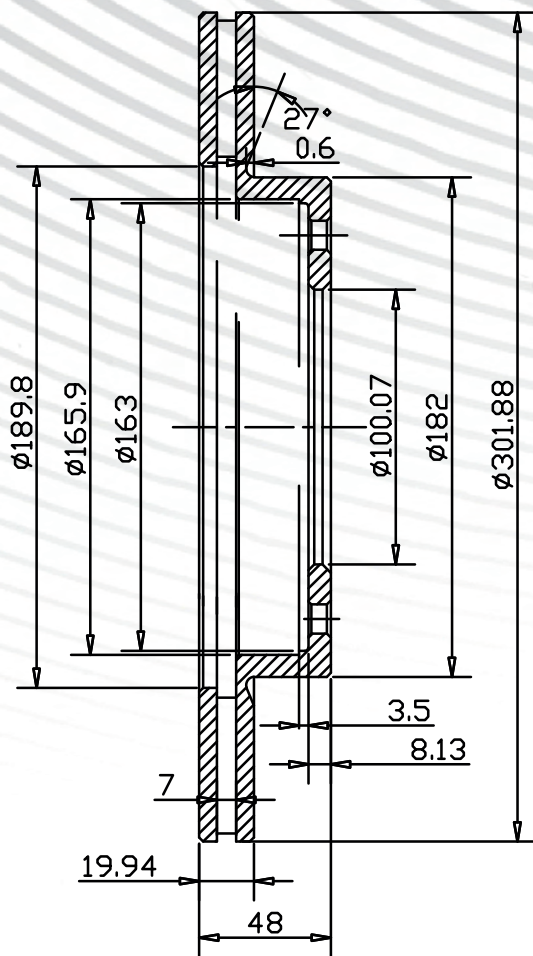

NPC DYNAMIK	FORMULACIÓN	ARMADORA	FREMAX	AÑO	DIÁMETRO	ALTO	ESPESOR	EJE
DNKD436STH	SMOOTH	TOYOTA	BD6004	0/01/1900	301,88 mm	48 mm	19,94 mm	DELANTERO
APLICACIÓN								
LAND CRUISER 4.5cc 24V 4X4								

DNKD606STH

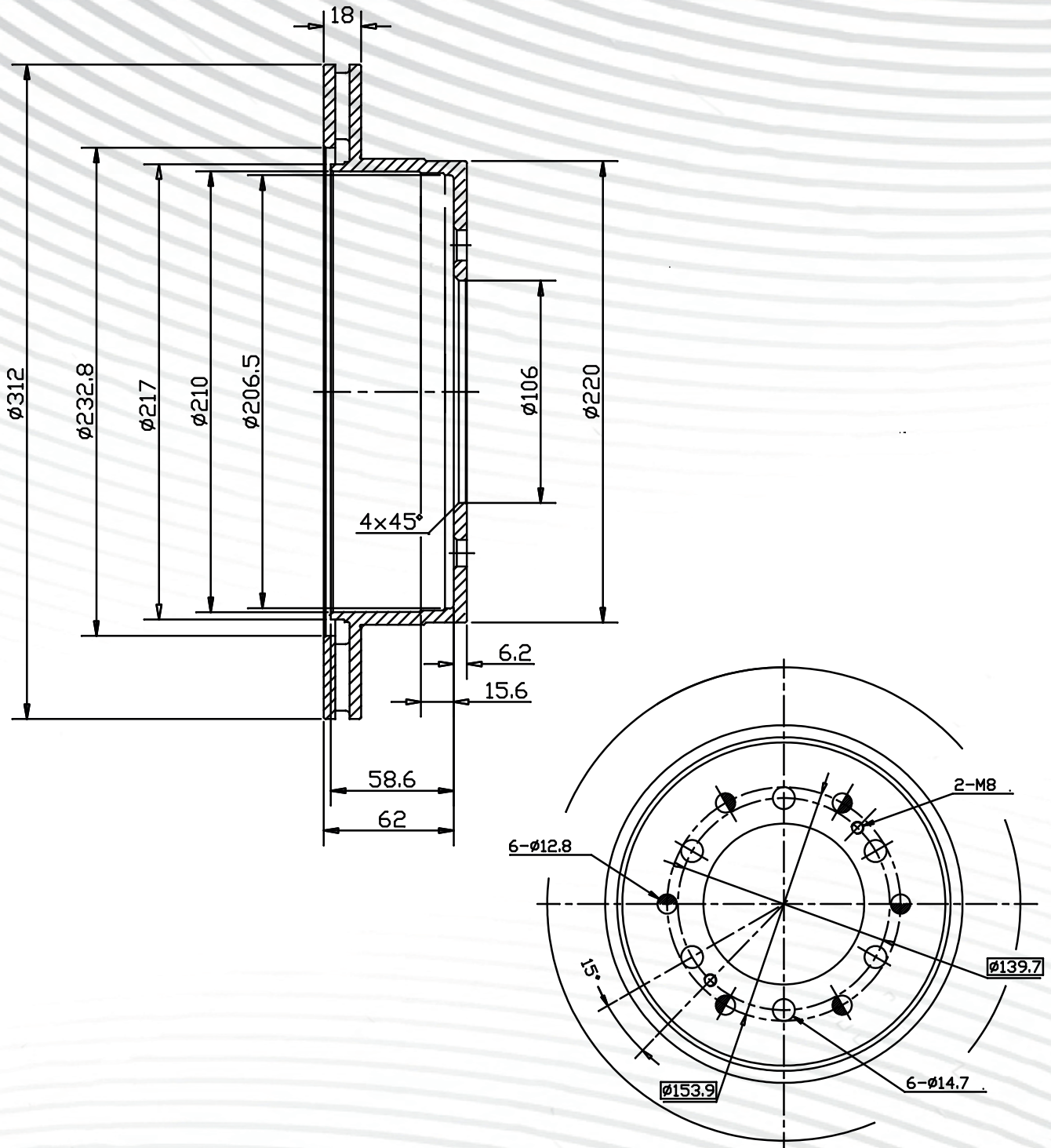

NPC DYNAMIK	FORMULACIÓN	ARMADORA	FREMAX	AÑO	DIÁMETRO	ALTO	ESPESOR	EJE
DNKD606STH	SMOOTH	TOYOTA	BD2919	02/...	312 mm	68,2 mm	18 mm	TRASERO
APLICACIÓN								
PRADO 3.0cc-3.4cc-4.0 cc V6 / FJ CRUISER 4.0cc V6/ FORTUNER 3.0cc-4.0cc V6 / 4 RUNNER IV 4.0 V6-4.7 V8								

DNKD773GMS

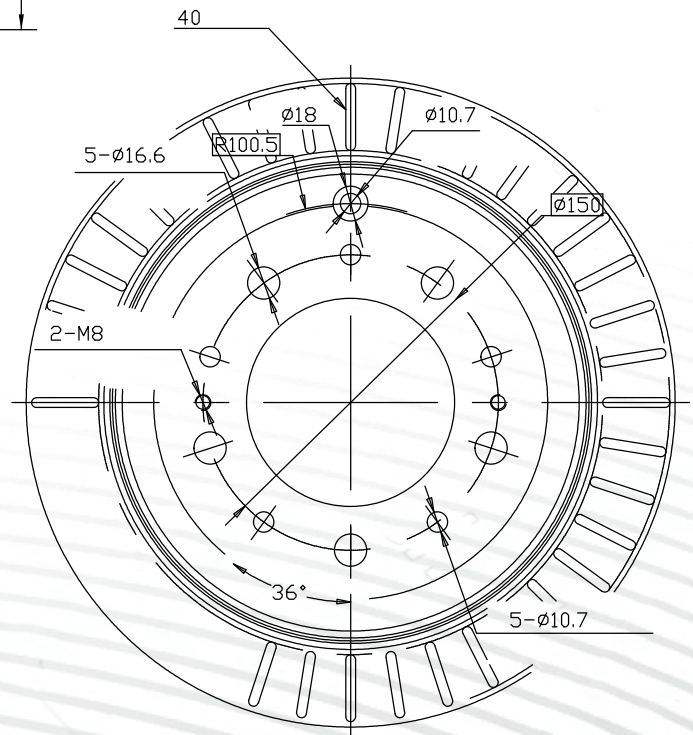
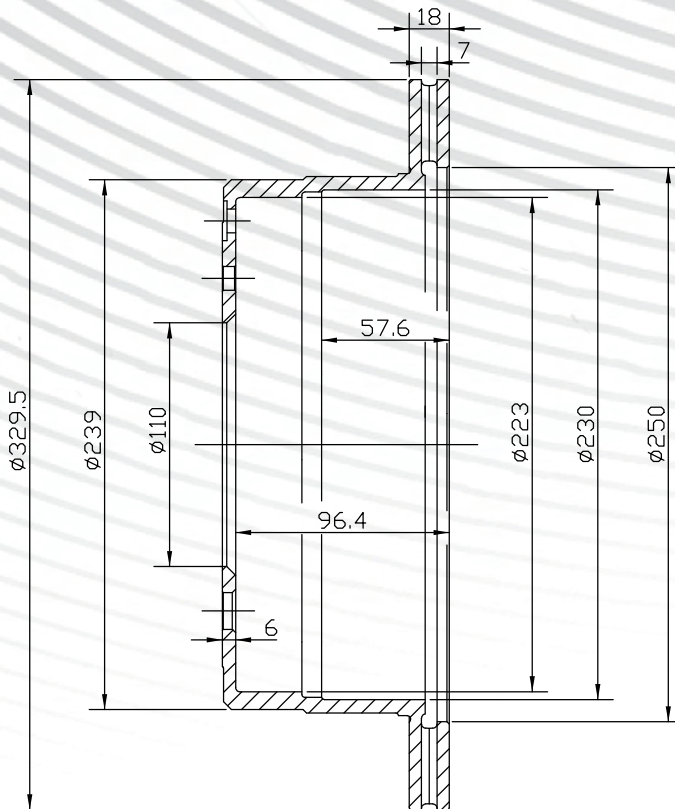

NPC DYNAMIK	FORMULACIÓN	ARMADORA	FREMAX	AÑO	DIÁMETRO	ALTO	ESPESOR	EJE
DNKD773GMS	GEOMET	TOYOTA	BD1264	98/07	329,5 mm	102,4 mm	18 mm	TRASERO
APLICACIÓN								
TOYOTA LAND CRUISER PRADO 1998-2007 ; LEXUS LX 470 1998-2004								

DNKD976STH

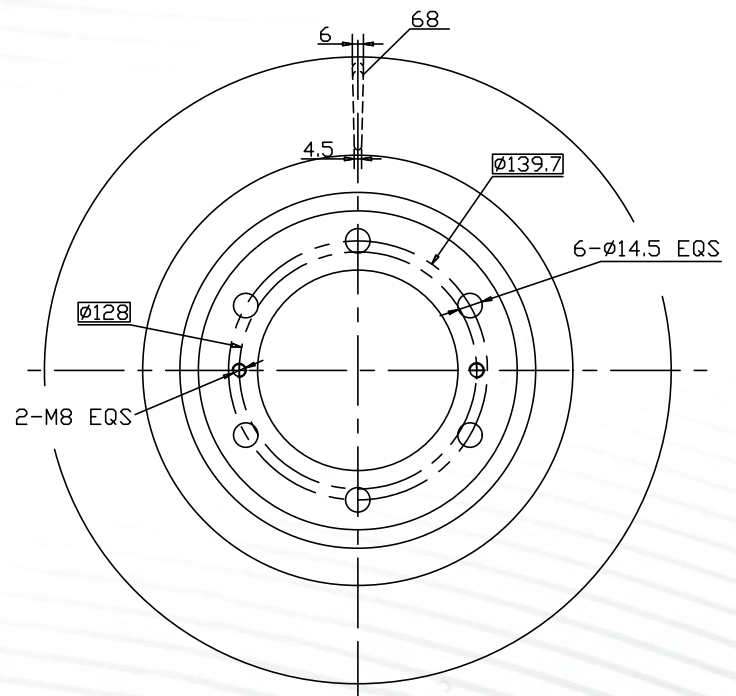
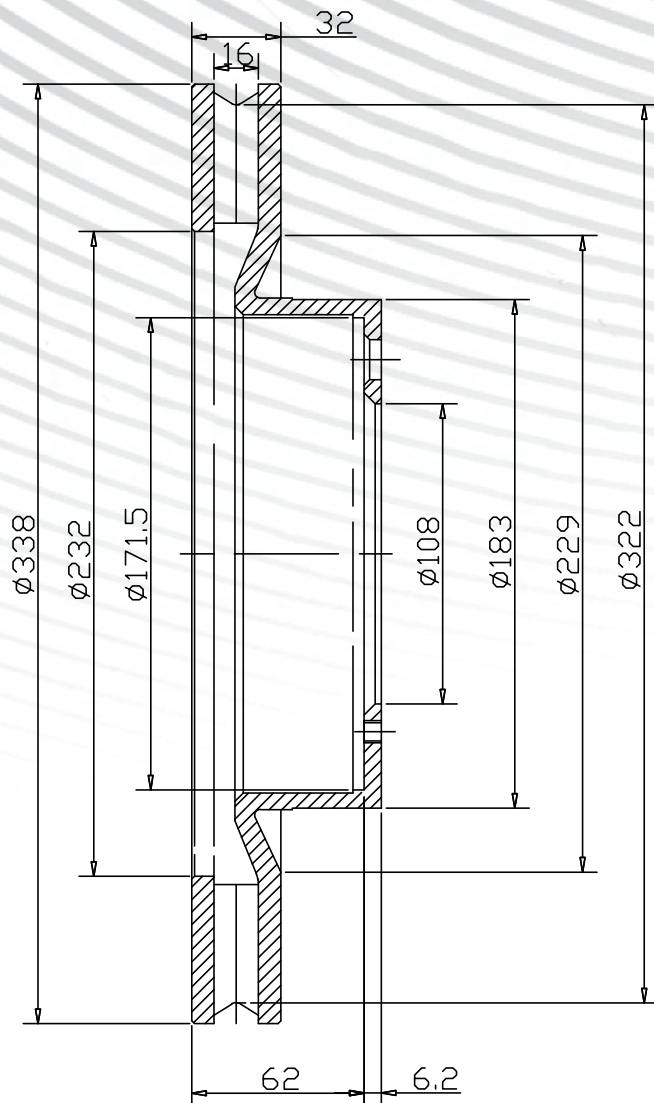

NPC DYNAMIK	FORMULACIÓN	ARMADORA	FREMAX	AÑO	DIÁMETRO	ALTO	ESPESOR	EJE
DNKD976STH	SMOOTH	TOYOTA	BD2916	10/...	338 mm	68,2 mm	32 mm	DELANTERO

APLICACIÓN

4RUNNER SR5 (GRN280) 4.0cc V6 24v 4WD
 4RUNNER LIMITED (GRN285) 4.0cc V6 24v 4WD
 PRADO TX / TX-L (KDJ150) 3.0cc TD 16v 4WD
 PRADO TX / TX-L (GRJ150) 4.0cc V6 4WD
 PRADO TX SUMO (TRJ150) 2.7cc 16v 4WD
 PRADO VX / VX-L (KDJ150) 3.0cc TD 16v 4WD
 PRADO VX / VX-L (GRJ150) 4.0cc V6 4WD

DNKD694STH

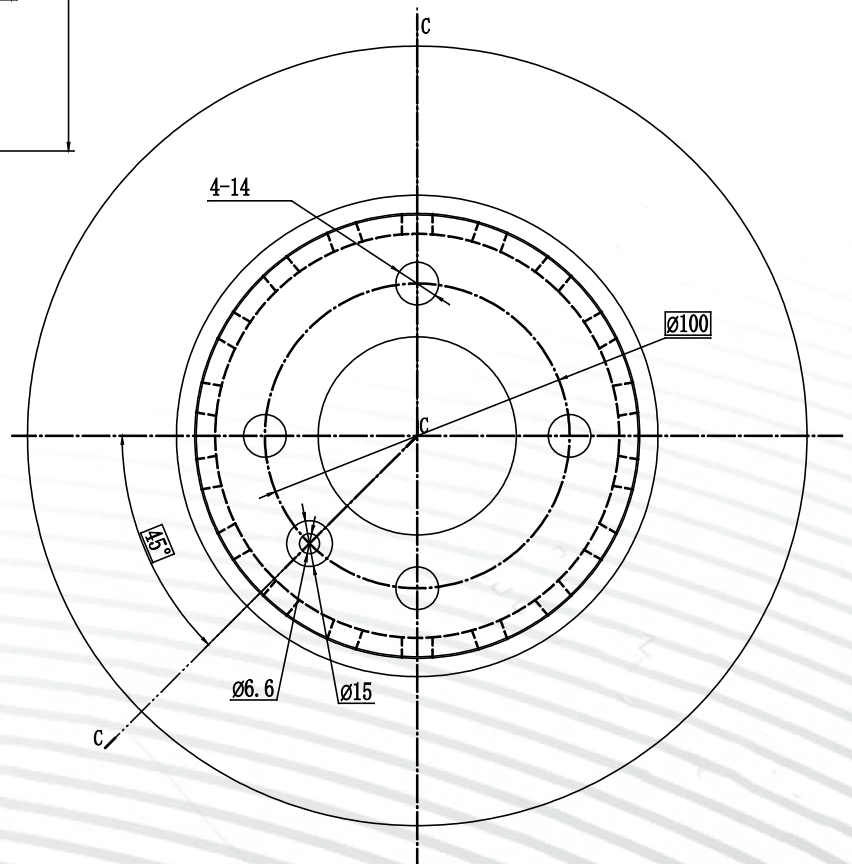
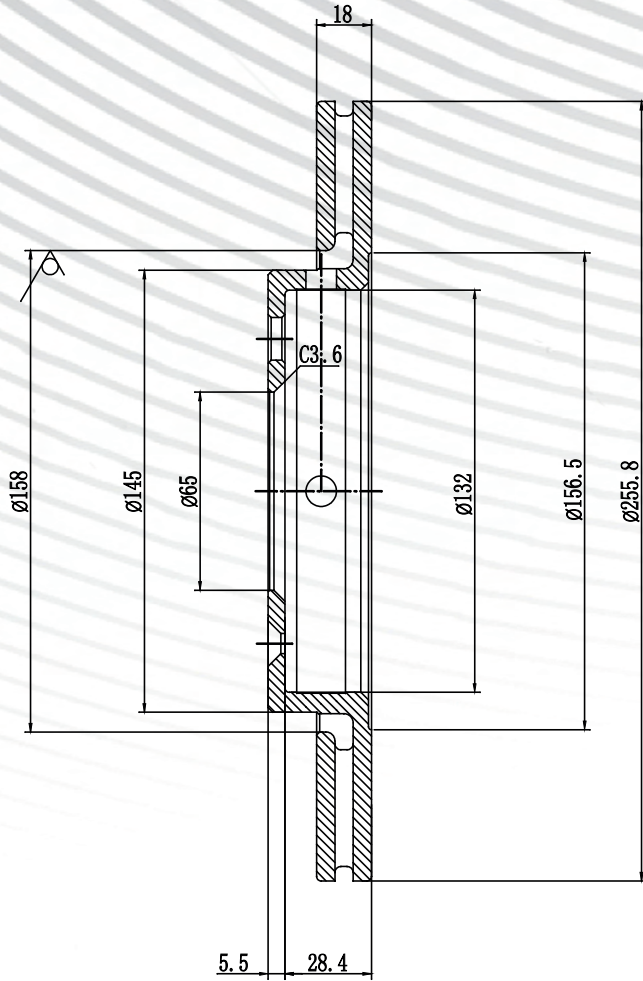

NPC DYNAMIK	FORMULACIÓN	ARMADORA	FREMAX	AÑO	DIÁMETRO	ALTO	ESPEJOR	EJE
DNKD694STH	SMOOTH	VOLKSWAGEN	BD5297	08/...	255,8 mm	33,9 mm	18 mm	DELANTERO
APLICACIÓN								
NUEVO GOL 1.6cc - 1.8cc (Rin 14)								

CROSS REFERENCE

DYNAMIK NO.	FREMAX	BEX USA	HIPER FREIOS	BRAKEPAK	MDS / FRASLE	BREMBO	TEXTAR	BENDIX	OEM	ARMADORA	PÁGINA
DNKD1456STH	BD5637		HF88G	DF-0645	D35H	08B41310	92224903		1K0615601AA-5QD615601A-5QX615601D-6R0615601	AUDI	3
DNKD296STH	BD1160	BXDI-0736	HF304	DF-0052	D191A				30005701-96052404-5531160B11-5551182000-5551182000-5531160811-5531160B11-5531160B11A00-55311A60B11-555118200	CHEVROLET	4
DNKD451STH	BD6030			DF-0055	D191	9585710	92069000	561650B	96067908-5531180F00-5531160B30-5531180F01-5531180F02-5531160B20-5531170F01-5531180F01A00-55311M72F00	CHEVROLET	5
DNKD677STH	BD6101	BXDI-0719		DF-0053		8727910	92093200	562117B	5531161G00-5531161G00A00-5531161G01-5531161G01A00	CHEVROLET	6
DNKD1321STH	BD4392	BXDI-0711		DF-0050	D531 - FLD000412	8782210	91000300	562138B	96455424-96254392-96284392-96320531-96455424-96320531	CHEVROLET	7
DNKD1661STH	BD1570					9670810	92278703		13584676-569130	CHEVROLET	8
DNKD688STH	BD1440	BXDI-0728HL		DF-0030	D17	9960710	92029603	520447	90008006-90121445-9051111-93281952-93288401-90121445-40206U7601-40206U7600-9005088	CHEVROLET	9
DNKD1176STH	BD7966	BXDI-0723		DF-0031	D28A	9863575			91277965-91277966-569021	CHEVROLET	10
DNKD1677STH	BD6039	BXDI-0707		DF-0033	D828A	09A30510			8972382720-8973088680-8973606760	CHEVROLET	11
DNKD227STH	BD3606	BXDI-0704	HF26E	DF-0565	D531A				24510381	CHEVROLET	12
DNKD797STH	BD8338	BXDI-0713		DF-0045	D27			522044	963283398-96549782-96264591-96549782-96328338	CHEVROLET	13
DNKD363STH	BD2376	BXDI-0733		DF-0042	D828	9557710	92075800	561643B	53707-8941723761-8943619271-94172376-569801-596210-8941723761-8943619270-8943619271-8943724350-94172376-94172376	CHEVROLET	14
DNKD1036STH	BD6028	BXDI-0717		DF-0046	D27A	08A87210	92163000	521489	96549630-96549630	CHEVROLET	15
DNKD138STH	BD6006			DF-0016						CHEVROLET	16
DNKD1039STH	BD6780	BXDI-0714		DF-0034	D828B	09B26710	92174803		8973606760-8973606780-8973606770-8980062590	CHEVROLET	17
DNKD556GMS	BD2863			DF-0070	D192E	9914210	92136800	520825	5521165D01-5521167D01	CHEVROLET	18
DNKD660STH	BD6970	BXDI-0720		DF-0047	D192B	8526610	92066000	561505B	96058796-5521160A00-5521160A01-5521180A00-9998560A00	CHEVROLET	19
DNKD1467STH	BD1553	BXDI-0703		DF-0061	D192G - FLD000704	09B35620		521662	13502059-569091-13502059	CHEVROLET	20
DNKD1676GMS	BD3970	BXDI-0738		DF-0035	D18G	09C24410	92282403		98124663-8981246633-8981246634-8981246643	CHEVROLET	21
DNKD378STH	BD9042		HF25		D48	9514820	982000392	561488B	569001-90250546-9048702-96179110-569042-902955087	DAEWOO	22
DNKD350STH	BD1815			DF-0116		8475310	92034500	561326B	5961814-71738423	FIAT	23
DNKD1563STH	BD5212			DF-0590	D36G - FLD00051	09D21611	92279003		CN151125A-CN151125CA-1781236-1805749-1854394-2026104-CN151125AA-CN151125AB-CN151125CA-CN151125DA	FORD	24
DNKD1044STH	BD5211		HF18E		D36B				4S4Z1125AA	FORD	25
DNKD1573GMS	BD6032	BXDI-2405		DF-0161	D33I	09B62210	92223000	522131	1490412-2M341027AA-4429562-6M341027DA-UM6133251-UR6133251	FORD	26
DNKD1142STH	BD0550	BXDI-1821		DF-0195	FLD000496 / D098B				5171202550-5171202551	HYUNDAI	27
DNKD1684STH	BD7500	BXDI-1801HL		DF-0208	D251D - FLD000533	9950310	92147100	562428B	517120X500-5171207500-51712X7500	HYUNDAI	28
DNKD497STH	BD1008		HF102A		D099A	9953710		562273B	5171225010-5171225061-5171225060	HYUNDAI	29
DNKD497GMS	BD2135	BXDI-1824			D099	9500410	92062600	561521B	5171221350-5171221A00-5171221B00-5171221400-51712232300-5171232A00-5H16131000-5H16131010-5H1631000-5H1631010	HYUNDAI	30
DNKD1935STH	BD7510	BXDI-1802			D251E - FLD000729	09A86710	92196500	562555BC	5171207700-517120X700-51712B9000-S5171207700-S517120X700	HYUNDAI	31
DNKD1156GMS	BD5101	BXDI-1803		DF-0196		09A44511	92164700	562554BC	517121G000	HYUNDAI	32
DNKD1157GMS	BD0581			DF-0202	FLD00077 / D325E				584111H100-584111H300-KIA 584111H100	HYUNDAI	33
DNKD1447STH	BD5171	BXDI-2219		DF-0204	D325A - FLD000509	09A70611		562433B	517121D100-517121F300-517121H000-517121H100-517122C000-517122K100-517122L000-517123K000-517123K010-517123K050-517121F000-517122E305-517122G000-517123K50	HYUNDAI	34
DNKD1593STH	BD6207									HYUNDAI	35
DNKE465STH	BD7501				FLD01532				51712G6000	KIA	36
DNKD1593GMS	BD5206	BXDI-1827		DF-0537	D099C	09C17110	92237903		517120U000-517121S300-517121W200-517121W250-51712C8000-517121R000	KIA	37
DNKD320STH	BD0001	BXDI-2411	HF351	DF-0232	D251	9595710		520222	505333251-OKX4333251-S08333251-UB3933251A	KIA	38
DNKD1544GMS	BD5201				FLD01328	08C17210	92242203		584110U300	KIA	39
DNKD1397STH	BD5158	BXDI-1828		DF-0617		9957441	92162603	521292	517121H100-517121M000-517122K100	KIA	40
DNKD1759GMS	BD0169					09D06511	92300903		D09T33251-DA7R33251-DA6A33251A	MAZDA	41

CROSS REFERENCE

DYNAMIK NO.	FREMAX	BEX USA	HIPER FREIOS	BRAKEPAK	MDS / FRASLE	BREMBO	TEXTAR	BENDIX	OEM	ARMADORA	PÁGINA
DNKD1454GMS	BD6036	BXDI-2407		DF-0218	D253B	09A96814	92166800	562564BC	D09T33251-DF7133251	MAZDA	42
DNKD1679STH	BD3276				FLD01082	8997521		521115	BP6Y26251B-BP6Y26251C-BP6Y26251D-BP6Y26251E-C25Y26251A-C25Y26251B-C25Y26251C	MAZDA	43
DNKD1044GMS	BD3563			DF-0607			92267503		B45A33251A-BJS733251A	MAZDA	44
DNKD1759STH	BD3565				FLD01145	09C65211		521700	B45G33251A-BJT23351A	MAZDA	45
DNKD399STH	BD3260									MAZDA	46
DNKD2038GMS	BD4758	BXDI-2724	HF615D		FLD01272				402065R80A-402065RA2A	NISSAN	47
DNKD1345STH	BD4738	BXDI-2716		DF-0318	D921	09B52610			40206EE320	NISSAN	48
DNKD1592STH	BD4740	BXDI-2718		DF-0562	D921A		92290103		402063U800-402063U80A	NISSAN	49
DNKD333STH	BD6744				FLD00608	9674410		520232	4020602N00-4020602N01-4020609G03-402065T500-40206VY10A	NISSAN	50
DNKD1191STH	BD5205	BXDI-2705	HF600D	DF-0351	D560D				40206VW000-BFR520510-40206VW601	NISSAN	51
DNKD1338STH	BD4206			DF0347	D922A	09B63210	92269203	521193	40206EM10A-40206ET01C-40206ZW90A	NISSAN	52
DNKD1911STH	BD4198			DF-0324	D200B	09D61911	92285800	BDS1536	402064KJ1B-40206JR70B-40206JR70C-40206JR70D-92285803	NISSAN	53
DNKD1737GMS	BD2089	BXDI-2725		DF-0614	FLD00739	09C54510			402064BA0A-402064BT0B-402064EA0A-402064EA0B-402066624R-D02064CL0A-402066624R	NISSAN	54
DNKD371STH	BD4705	BXDI-3041		DF-0370	D705			561235B	2677509716-6001547684-6001549211-8671000083-7700674765-7700704705-7701204282	RENAULT	55
DNKD1830STH	BD3108	BXDI-3040		DF-0481	D705E - FLD00698	09C28510	92241503		402062212R-402063149R-402063166R-402066839R-402067025R-402067615R-4534200100-8660003934-4534200100	RENAULT	56
DNKD1146STH	BD3550	BXDI-3022		DF-0373	D653 - FLD00086			561997B	6001548578-7701204304-7701205653-7701206339-8201464598-8671005976-8671013532-8671016876-8671018195-4020600Q0E-4020600Q0K-4020600QAA-7700780892-7700813549-7700842131-7701204228-7701204828-7700780892-7700813549-7700842131-7701204304-7701204828-7701205653-7701206339-8201464598	RENAULT	57
DNKD340STH	BD4023KT			DF-0368	D705D	08B36917		522079	432001539R-432007595R-432001868R-432007595R	RENAULT	58
DNKD1627STH	BD4022	BXDI-3032	HF571	DF-0545	D705C	09A72710	92195503	562529BC	402060010R-402063793R-402064151R-8660001232-4020600QL-4020600Q1B	RENAULT	59
DNKD1736STH	BD2059	BXDI-3008HL		DF-0389	D842F	09A71621		521194	40206ET01A-40206JE20A-40206JY01A-40206JY01A-402069828R-40206JY01A-40206JY01A	RENAULT	60
DNKD303GMS	BD5180			DF-0415	D343E	9501710	92050400	561442B	4351226040-4351226070-4351235180-4351235260-4351235180	TOYOTA	61
DNKD436GMS	BD5190	BXDI-3610HL		DF-0416	D190	9517314	92076300	561502B	J4351235190-4351235110-4351235190-4351235270	TOYOTA	62
DNKD1567STH	BD4211	BXDI-3606		DF-0428	D343D - FLD00021	09A63410	92222600	522082	435120K060-435120K070	TOYOTA	63
DNKD436STH	BD6004	BXDI-3626		DF-0432	D343B - FLD00664	9567910	92080400	561444B	4351235170-4351260040-4351260041-4351260100-4351269015-4351269016-J4351235170-J4351235170	TOYOTA	64
DNKD606STH	BD2919	BXDI-3617		DF-0419	FLD00256	09A33410	92170103	520857	4243160130-4243160200-4243160201-4243160190-6243160200-6243160270-6243160295-4243160270	TOYOTA	65
DNKD606GMS	BD2917	BXDI-3602		DF-0576	D343I - FLD00708	09A33421	92231003	521523	4243160311-4243160311	TOYOTA	66
DNKD773GMS	BD1264	BXDI-3608		DF-0426	FLD00755				4243160220-4243160221-4243160280-4243160281-4243160220	TOYOTA	67
DNKD976STH	BD2916	BXDI-3607		DF-0581	D343H - FLD00733	09B63411	92223903	562828BC	4351260190-4351260190-4351260191	TOYOTA	68
DNKD694STH	BD5297	BXDI-3716	HF87A	DF-0517	D31E - FLD00096				5U0601301C	VOLKSWAGEN	69



dynamik
carboceramic

WWW.CIOSA.CO